

YOUR HUNT IS OVER.

**THE QUICK, SLY, CRAFTY,
CUNNING FOX
BY AUDI
IS HERE.**



A Fox is smart. Sleek. And ours is no different. The Audi Fox is a smart little sports sedan that's precisely engineered, inside and out. How does it run? Like a sports car. How spacious is it? Like a sedan.

The Audi Fox is nobody's hand-me-down. It's a special combination of sports car precision and sedan comfort. It has a brand new engine, chassis and body. It has excellent performance and above average acceleration in its class, along with interior roominess and luggage space. Features you won't find combined in other cars. Not even other Audis. Our Fox is easy to take care of. Doesn't eat much either. About 23 mpg.*

So don't fall for another fable. Take a look at the Fox. It's a true sports sedan. And that's no story.



NOT JUST ANOTHER FABLE, A TRUE SPORTS SEDAN. FOX BY AUDI.



QUICK TO THE CHASE, CLEVER IN TIGHT CORNERS, LEAN PERFORMANCE

A Fox knows how to take care of himself. He can run when he has to. Get out of tight places. Stop in his tracks. Just like an Audi Fox.

Ours takes off fast. 0 to 50 in 8.5 seconds. (In 10 seconds with automatic transmission.) It runs all day without tiring. And stops surely with the help of power-front disc brakes.

Corner our Fox and what happens? Rack-and-pinion steering, along with independent front suspension and a torsion crank axle in the rear, lets you maneuver nimbly and easily. Follow the trail wherever it leads. And take the sharpest turns in stride.

Though Foxes like to run in uncrowded places, ours performs well in town too. It calmly sits through traffic jams. Starts and stops again without complaints. Gets in and out of tight parking spaces with agility. Then it's back to the open road, where once again the chase is on.



FOX BY AUDI



CRAFTY ENGINEERING, PRECISELY BUILT TO HOLD ITS GROUND.

CENTRALIZED ELECTRICAL CONTROL PANEL

Conveniently locates all fuses and relays up front in the engine compartment.

OVERHEAD-CAM ENGINE

4-cylinder in-line engine, designed with a light-alloy cylinder head to perform smoothly at all speeds and run easily at high speeds.

INDEPENDENT FRONT SUSPENSION

McPherson struts and a stabilizer bar help each wheel to handle bumps independently for a smoother ride and a better control.

SELF-STABILIZING STEERING

Steering system with an uncommon geometry that'll automatically compensate for uneven front-wheel braking effects due to slippery roads, tire or partial brake failure.

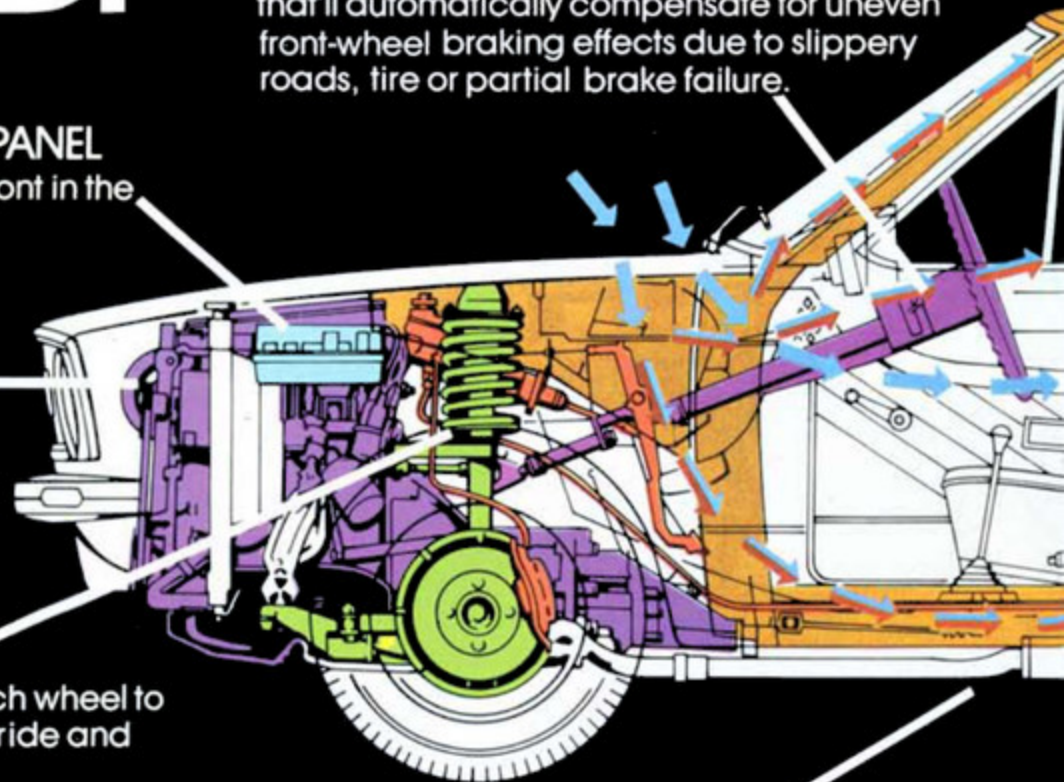

UNITIZED CONSTRUCTION

Body and floor pan are welded into one rigid unit.

INERTIA-REEL BELTS

3-point seat belts in front, which are comfortable, easy to move in, yet lock tight when maximum protection is needed.

FLOW-THROUGH VENTILATION

Fresh-air heating and ventilation for greater inside comfort, plus vents and ductwork that allow installation of optional air conditioning.

REAR-AXLE STABILITY

Torsion-crank rear axle with Panhard rod and stabilizer for excellent tracking and cross-wind stability.

DUAL CIRCUIT BRAKES

A system of power brakes, discs up front and drums in the rear, diagonally paired to give you controlled stops, even if one pair should fail.

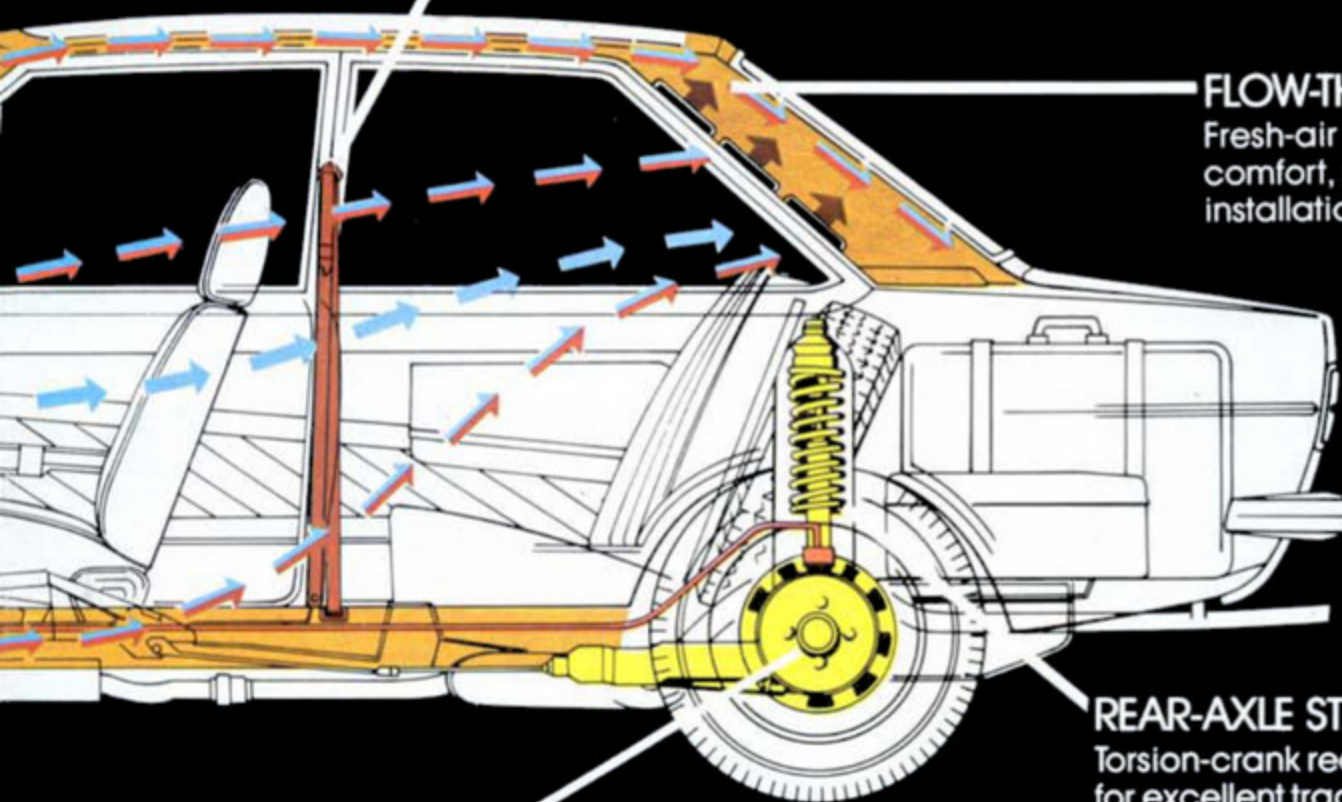



Our Fox is well equipped with standard items such as aluminum bumpers. PVC undercoating. Radial tires. And power front disc brakes. Inside are child-proof rear-door safety locks. Inertia-reel seat belts. Illuminated glove compartment. Coat hooks. A cigar lighter. Features that don't cost a penny more.

But like most Foxes, ours can adapt quickly. For a little extra you can add a sliding steel sunroof. Or if things get too hot, one of our custom-fitted air conditioners. And if you'd like your Fox to shift for itself, put it through its paces with our optional automatic transmission. You can also add leatherette upholstery. A vinyl roof. AM-FM radio. Or AM alone.

Ask your Dealer about these and our other options. He's a man who knows how to make your Fox adapt.

**CUNNING ADAPTABILITY
WITH THE OPTION TO
OUTFOX THE OTHERS**





FOX BY AUDI

SPECIFICATIONS—THE FOX BY AUDI/1974

ENGINE:	Type	4 cylinder—4 stroke cycle—In line
	Location	Front mounted—20° slanted
	Bore	3.01" (76.5mm)
	Stroke	3.15" (80.0 mm)
	Displacement	89.7 cu. in. (1471 cc)
	Compression ratio	8.2:1
	Horsepower	75 SAE net at 6000 rpm
	Carburetion	1 2-stage downdraft carburetor
	Cooling	Water cooled, with thermostatically controlled electric fan
	ELECTRICAL SYSTEM:	Ignition
Battery		12 volt, 54 Amp hour
Alternator		770 watt
DRIVE TRAIN:	Type	Front wheel drive
	Standard Transmission	4-speed, fully synchronized
	Optional Transmission	3-speed, fully automatic
STEERING:	Type	Rack and pinion
	Turns—lock to lock	3.94
	Turning Circle	32'
BRAKE SYSTEM:	Type	Hydraulic, power-assisted with diagonally linked dual circuits
	Front Brakes	Disc brakes—9.4" diameter with integral wear indicator
	Rear Brakes	Drum type—7.85" diameter
	Total Effective Brake Area	61.5 sq. in.
CHASSIS AND SUSPENSION:	Frame	Unitized body with subframe
	Front Suspension	Independent McPherson struts with negative steering roll radius
	Front Springing	Coil springs and shock absorbers, plus stabilizer bar
	Rear Suspension	Torsion crank axle, with Panhard Rod
	Rear Springing	Coil springs and shock absorbers
RIMS AND TIRES:	Wheel Size	5 JX 13
	Tire Size	155 SR 13 Radial ply tires
DIMENSIONS:	Wheelbase	97.2"
	Front Track	52.7"
	Rear Track	52.5"
	Overall length	172"
	Overall width	64.7"
	Height (unloaded)	53.6"
	Trunk Capacity	15.5 cu. ft.
CAPACITIES:	Engine oil	Approx. 3 quarts U.S./2.5 Imp. quarts
	Cooling system	6.5 quarts U.S./5.4 Imp. quarts
	Fuel Tank	12 gallons U.S./10 Imp. gallons
	Fuel Requirement	Regular grade—91RON minimum

Specifications subject to change without notice.