

1983 Audi 5000 *turbo*

Audi
Owner's
Manual



Contents

| | page | | page |
|---|----------------|---|--------|
| Accelerator pedal | 46, 49 | Defogging/defrosting | 50 |
| Air cleaner | 71 | Dimensions | 89 |
| Air conditioner (option) | 50 | Do-it-yourself service | 54 |
| Alternator warning light | 27 | Doors | 10 |
| Ashtrays | 35 | Economical driving | 44 |
| Assist handles and coat hooks | 33 | Electrical adjustable seats | 15 |
| Automatic Transmission | 47, 87 | Electric heating for front seats | 15 |
| Automatic Transmission Fluid(ATF) | 74 | Electrical mirror | 13 |
| Battery | 76, 88 | Electrical system | 88 |
| Battery charging | 77 | Electric windows | 12 |
| Bell chime | 9, 23 | Emergency equipment | 65 |
| Brakes | 45, 87 | Emergency flasher | 31 |
| Brake fluid reservoir | 75 | Emergency starting | 48, 78 |
| Brake warning light | 22, 28, 46 | Emergency starting assist | 23 |
| Break-in period | 5 | Emergency towing | 91 |
| Bulb chart | 57 | Emission Control System | 83 |
| Bulb replacing | 58 | Engine exhaust | 44 |
| Capacities | 88 | Engine hood | 41, 68 |
| Catalytic converter | 43, 78, 84, 85 | Engine number | 8 |
| Central locking system | 11 | Engine oil changing | 70 |
| Chassis number | 8 | Engine oil checking | 69 |
| Child proof lock | 11 | Engine oil grades | 90 |
| Cigarette lighter | 35 | Fan | 51 |
| Cleaning | 54 | Foreign country driving | 4 |
| Clock | 36 | Fuel gauge | 26 |
| Compact spare wheel | 61 | Fuel supply | 43, 86 |
| Cooling system | 64, 72 | Fuses and relays | 56 |
| Cruise control | 38 | Gas Station Information | 91 |
| | | Gasohol | 43 |
| | | Gasoline | 43, 86 |
| | | Glove compartment | 34 |
| | | Headlights | 30, 58 |
| | | Headlight dimmer and flasher | 30 |
| | | Headlight switch | 30 |
| | | Head restraints | 17 |
| | | Heating/Ventilation | 50 |
| | | Height adjustment for driver's seat | 14, 15 |
| | | High beams | 29, 30 |
| | | Hood release | 41 |
| | | Ignition/steering lock | 22 |
| | | Indicator lights | 27 |
| | | Instrument illumination | 32 |
| | | Instrument panel | 21 |
| | | Interior light | 33, 60 |
| | | Jack | 61 |
| | | Jack supports | 93 |
| | | Keys | 9 |
| | | Kickdown | 49 |
| | | Lane changer | 30 |
| | | License plate lights | 60 |
| | | Lifting car | 92 |
| | | Lights | 30, 58 |
| | | Locks | 11, 40 |
| | | Lubricants | 90 |
| | | Luggage compartment | 40 |
| | | Mirrors | 13, 34 |
| | | Neutral | 49 |
| | | Note to owners | 2 |

| | page |
|--|------------|
| Oil change | 70 |
| Oil filter changing | 70 |
| Oil pressure warning light | 28 |
| Parking brake | 46 |
| Parking lights | 30 |
| Power assisted steering | 71 |
| Power windows | 12 |
| Reading lights | 36 |
| Rear view mirror | 13, 34 |
| Rear window defogger | 32 |
| Relays | 56 |
| Reverse | 48 |
| Safety belt warning light | 28 |
| Safety compliance sticker | 8 |
| Safe driving hints | 6 |
| Safety belts | 18 |
| Seats | 14 |
| Selector lever | 47 |
| Ski sack | 16 |
| Sliding roof | 37 |
| Snow chains | 65 |
| Spare wheel | 61 |
| Spark plugs | 65, 73, 88 |
| Specifications | 87 |
| Speedometer | 24 |
| Speed ranges | 5 |
| Starting procedures | 42, 48 |
| Stopping engine | 42 |
| Sunroof | 37 |
| Sun visors | 34 |

| | page |
|---|------------|
| Tachometer | 25 |
| Technical data | 86 |
| Temperature gauge | 26 |
| Tires | 66, 67, 87 |
| Tools | 61 |
| Towing | 78, 91 |
| Troubleshooting | 79 |
| Turn signals | 30 |
| Undercoating | 85 |
| Unleaded fuel | 43 |
| V-belt | 73 |
| Vehicle identification number/label | 8 |
| Ventilation/heating | 50 |
| Warning lights | 27 |
| Water temperature gauge | 26 |
| Water temperature light | 28 |
| Weights | 89 |
| Wheel changing | 62 |
| Windows | 12 |
| Windshield washer fluid container | 75 |
| Windshield wiper/washer lever | 31 |
| Winter operation | 64 |

Before Driving

Operating Controls

Climate Controls

Do-it-yourself Service

Emission Control

Technical Data

Gas Station Information

NOTE TO OWNERS

In Canada, this manual is also available in French. To obtain a copy, contact your dealer or write to:

NOTE AUX PROPRIETAIRES

Au Canada, on peut se procurer un exemplaire de ce Manuel en français auprès du concessionnaire ou de:

Volkswagen Canada Inc.
Customer Assistance/Assistance à la Clientèle
1940 Eglinton Ave. East
Scarborough, Ontario M1L 2M2

About this Manual

- Your car may have all or some of the equipment described in this manual. Therefore you may find explanations of equipment not installed in your car.
- Check with your Audi dealer on available options or accessories.
- Text, illustrations and specifications in this manual are based on information available and valid at the time of printing.
- It has always been Audi's policy to continuously improve its products. Audi, therefore, reserves the right to make changes in design and specifications, and to make additions or improvements to its product, without incurring any obligation to install them on products previously manufactured.

BEFORE DRIVING

Your new Audi...

is the result of many years of technical research and endurance testing. It is a sophisticated product of engineering, a car designed for maximum efficiency and driving pleasure, a car designed with your safety in mind.

Your Owner's Manual...

contains a host of useful information. Read it before you drive your new car. Acquaint yourself with your car's features and know how to operate it more safely. The more you know about your Audi, the more you will enjoy driving it.

Your Warranty & Maintenance booklet...

FOR YOUR OWN PROTECTION and longer service life of your car, we ask you to heed our instructions and cautions. Ignoring them could result in extensive mechanical failure or physical injury.

explains how you can keep your Audi in top driving condition by having it serviced regularly. Always have the Warranty & Maintenance booklet with you when you take your car to an authorized dealer for service. Your Service Adviser will record each service.

The Warranty & Maintenance booklet also contains detailed information about the warranties covering your Audi. These warranties are: "Warranty for new Audi vehicles", "Warranty for new Audi vehicle Emission Control System" (USA and Canada), "Emissions Performance Warranty" (USA only), California Emission Control System Warranty (California, USA only).

The Owner's Manual and the Warranty and Maintenance record should be left in the vehicle when sold, to make all operating, safety and maintenance information available to the next owner.

If you bought this car as a USED CAR, be sure to send in a NOTICE OF USED CAR PURCHASE post card. This card can be found in the WARRANTY & MAINTENANCE booklet or obtained from your Audi dealer.

Operating your car outside the U.S.A. or Canada

Government regulations in the United States and Canada require that automobiles meet specific emission regulations and safety standards. Therefore cars built for the U.S.A. and Canada differ from vehicles sold in other countries.

If you plan to take your car outside the continental limits of the United States or Canada, there is a possibility that:

- **unleaded fuels for cars with catalytic converter may not be available;**
- **fuel may have a considerably lower octane rating. Improper fuel may cause engine damage;**
- **service may be inadequate due to lack of proper service facilities, tools or testing equipment;**
- **replacement parts may not be readily available.**

Audi cannot be responsible for the mechanical damage that could result because of inadequate fuel, service or parts availability.

Certain Audi models are available for delivery in Europe under our tourist delivery and return shipment program.

For details consult an Audi dealer or write to:

U.S.A. Volkswagen of America, Inc.
Audi Tourist Delivery
818 Sylvan Avenue
Englewood Cliffs, N.J. 07632;

Canada: Volkswagen Canada Inc.
Tourist Delivery
1940 Eglinton Avenue East
Scarborough,
Ontario M1L 2M2

If you bought your car abroad and want to bring it back home, be sure to find out first about shipping and forwarding requirements, as well as current import and customs regulations.

Break-in hints for the first 900 miles or 1,500 kilometers

By observing a few precautions during the first 900 miles or 1,500 kilometers, you help extend the service life and economy of your engine.

- Avoid full throttle starts and abrupt stops.
- Do not overstrain engine, select driving position before reaching top speeds.
- The maximum speeds as shown in the tables are for normal operating conditions after the engine has warmed up.

| Automatic Transmission | | |
|------------------------|-----------------|---------------|
| Driving position | up to 600 miles | up to 1000 km |
| D | 75* mph | 125* km/h |
| 2 | 50 mph | 85 km/h |
| 1 | 28 mph | 45 km/h |

During the next 300 miles or 500 km, the speed can be **gradually** increased.*

After the break-in period, the speed ranges are:

in D up to top speed.*
in 2 up to 75* mph or 125* km/h
in 1 up to 45 mph or 75 km/h

Make it a habit to accelerate gradually instead of using full throttle. During gradual acceleration the transmission shifts earlier into the next higher gear, thus saving fuel.

* Always observe all local and national speed limits!

OPERATE YOUR CAR SAFELY

A lot has gone into the manufacture of your Audi, including advanced engineering techniques, rigid quality control and demanding inspections. These engineering and safety features will be enhanced by you, the safe driver,

- who knows the car and all controls,
- who maintains the car properly,
- who uses driving skills wisely.

Before going on a trip . . .

- 1 – Be sure tires are inflated correctly. Check for damage and tire wear.
- 2 – See that wheel bolts or nuts are properly tightened and not loose or missing.

Turn the engine off before you attempt any checks or repairs on the car.

- 3 – Check engine oil level, add if necessary. Make it a habit to have engine oil checked with every fuel filling.
- 4 – Check coolant level to assure proper engine cooling.
- 5 – Be sure you have a well charged battery. Each cell should be filled to correct level with distilled water.
- 6 – Check brake fluid level. If too low, have brake system checked.
- 7 – Replenish windshield washer fluid.

- 8 – Replace worn or cracked wiper blades.
- 9 – See that all windows are clear and unobstructed.
- 10 – Check whether all headlight lenses are clean.
- 11 – Be sure all lights are working and headlights are aimed correctly.
- 12 – Check under car for leaks.
- 13 – Be sure all luggage is stored securely.

You'll find helpful hints on how to perform most of these checks in this manual. If in doubt, have these checks performed by your dealer or any other qualified mechanic.

In the driver's seat . . .

- 1 – Position seat for easy reach of controls.
- 2 – Use safety belts.
- 3 – Adjust inside and outside rear view mirrors.
- 4 – Depress center of steering wheel to check whether horn is working.
- 5 – Check all warning and indicator lights when starting the engine.
- 6 – Lock doors from inside, especially with children in the car.
- 7 – Check operation of foot and parking brakes.
- 8 – DO NOT leave car idling unattended.

On the highway . . .

- 1 – Always drive defensively. Expect the unexpected.
- 2 – Use signals to indicate turns and lane changes.
- 3 – Turn on headlights at dusk.
- 4 – Always keep a safe distance from the car in front of you, depending on traffic, road and weather conditions.
- 5 – Reduce speed at night and during inclement weather.
- 6 – Observe speed limits and obey highway signs.
- 7 – Never let car roll by its own weight with transmission in Neutral. Such coasting may lead to sudden loss of control and damage to transmission and engine, when a gear has to be engaged.
- 8 – When tired, get off the highway, stop and take a rest. Turn the engine off.

DO NOT sit in the car with engine idling. See warning on Engine Exhaust.

- 9 – When stopped or parked, always set the parking brake.
- 10 – When stalled or stopped for repairs, move the car well off the road. Turn on emergency flasher and use road flares or other warning devices to warn other motorists.
- 11 – Make it a habit to have the engine oil checked with every fuel filling.
- 12 – Check the coolant level and the ATF (automatic transmission fluid) regularly, even inbetween the recommended maintenance intervals.



The vehicle identification number

is located on the left windshield pillar so that it is visible from the outside through the windshield.

The Safety Compliance Sticker

can be found on the left doorjamb. It shows the month and year of production and the vehicle identification number of your car (perforation) as well as the **Gross Vehicle Weight Rating** and the **Gross Axle Weight Rating**.



The engine number

is stamped on the left side of the engine.

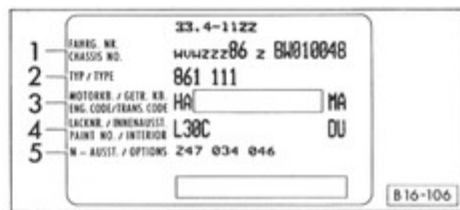

The vehicle Identification Label

is located on the inside rear lid. The label contains the following information:

1. Vehicle Identification Number
2. Vehicle Code
3. Engine and Transmission Code
4. Paint and Interior Code
5. Option Codes

A duplicate of the label is in your Warranty and Maintenance brochure.

OPERATING CONTROLS

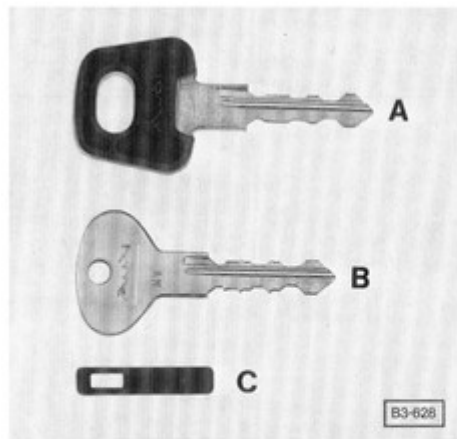

All keys can be inserted into locks either way.

Warning

Always remove the ignition key especially if children are left unattended in the car. Unsupervised use of power windows and electric sliding roof may cause serious injury.

Keys

Your Audi comes with two master keys and one auxiliary key.

Key A is the master key and fits all locks on the car, including the lockable tank cap.

Key B is only for the doors, the lockable tank cap and the steering/ignition lock. The luggage compartment and glove compartment cannot be opened with this key.

If you have to leave a car key with somebody else it may be advisable to give them this key only, if you are keeping valuables locked in the luggage compartment or glove compartment.

Plastic tag C gives the master key number.

Do not remove key from steering lock while you are driving or as the car is rolling to a stop. The steering column is locked when you remove the key, and you will not be able to steer the car.

For your protection against car theft:

- Record the key numbers first and keep them in a safe place, such as your wallet, **NOT IN THE CAR.**
- If you should lose a key, provide your Audi dealer with the key number to obtain a duplicate key. Tell him whether you need a master or auxiliary key.
- Do not leave your car unattended with the key in the ignition lock. Take the key and lock the doors.

A bell chime will sound when you open the driver's door with the key in the ignition lock. This is your reminder to remove the key and lock the doors.

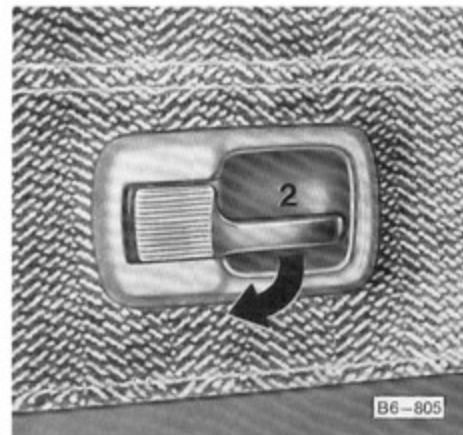
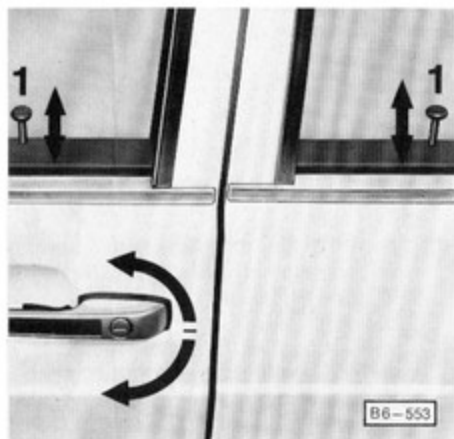

Doors

To lock, unlock and open doors from the outside

- Lock and unlock the front doors by turning the key to the right or left.
- Open the doors by squeezing the trigger in the outer door handle. On the rear doors raise locking knobs (1) first.
- All doors (except driver's door) can be **LOCKED** by first depressing locking knob (1) and closing the door.

- The **DRIVER'S DOOR** can only be locked from the outside with the key. This precaution was taken to prevent locking the driver's door while the key is still inside the car.

Always drive with locked doors to prevent inadvertent opening of a door from the inside, especially with small children in the car.

To lock, unlock and open doors from the inside

- To **LOCK** doors depress the locking knob (1). This will prevent opening the doors from inside and outside.
- To **UNLOCK** doors raise the locking knob (1).
- To **OPEN** doors pull the inside door handle after raising the locking knob (1)

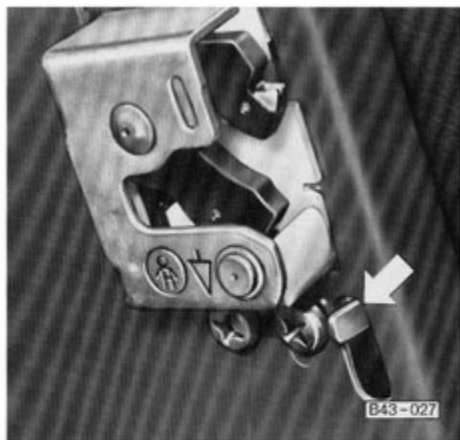

Central locking system

The central locking system locks or unlocks doors and trunk lid simultaneously. It is actuated from the driver's door.

All locks can be locked and unlocked individually with the key; manual lock operation will override the power lock system.

Locking/unlocking from the outside

- Lock or unlock doors and trunk lid simultaneously by turning key in lock of driver's door.

Locking/unlocking from the inside

- Raise or depress locking knob on window sill of driver's door.

When you have unlocked the driver's door with the key, wait until all locking knobs are raised before you open one of the doors.

The locking knobs on window sills should move simultaneously when the central locking system is actuated. If one knob does not move, open that particular door and close it properly.

Warning

Do not leave small children in the car without supervision. If the locking knob of the driver's door is depressed, all doors are locked, preventing access without a key in an emergency.

Trunk lid key slot turned to horizontal position (unlocked)

Trunk lid can be locked and unlocked by central locking system.

To open only trunk lid with actuated central locking system

- Turn master key in the trunk lid slot to right as far as it will go.
- Pull the lever under lid and lift lid.

Key slot in vertical position (locked)

Trunk lid remains locked when actuating central locking system. This provision has been made to facilitate permanent locking of the trunk lid when leaving your car in a public garage or workshop. Take master key with you and leave ignition/door key with attendant (also see page 40).

While master key is for all locks, the secondary key is for ignition switch and door locks only (see page 9 for more details).

Child lock for rear doors



To prevent children riding in the back seat from accidentally opening the rear doors, a safety mechanism is provided.

- To engage child lock, move small lever near lock latch DOWN (arrow).
- Close door and check whether child lock is securely engaged. It is securely engaged if rear door cannot be opened from the inside with locking knob in either raised or depressed position.

Rear door can be opened from the outside only when locking knob is raised.



B6-666

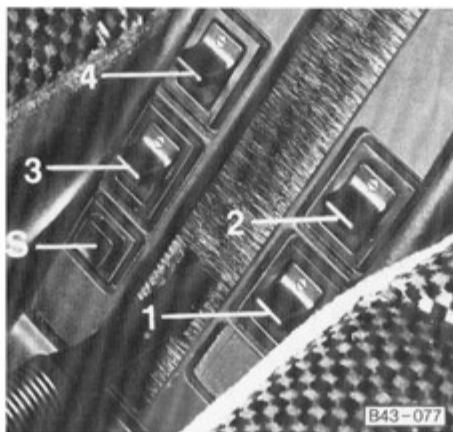

B43-077

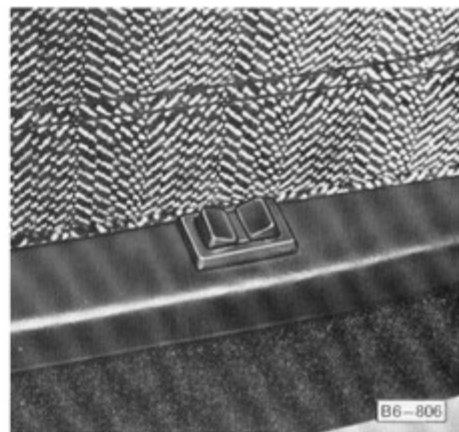

B6-806

Windows

Lower and raise the windows in the doors with the **winders**.

Cars with vent windows

To open – Press button in fastener and turn fastener forward.

To close – Press vent window against seal at the front, then swing fastener to the rear.

Do not put decals or other signs on the windows of your car. They may interfere with the driver's vision.

Power windows

The illuminated window control switches are located in the center console between the front seats and work only with the ignition on.

1 – front left 2 – rear left
3 – front right 4 – rear right

S – Safety switch for rear windows and cigarette lighters in the rear doors (see page 35).

- To open window – push switch down
- To close window – push switch up

www.audi-klassik.de

Control switches for rear windows are located in the rear door panels.

The rear windows can only be opened and closed when the safety switch (S) in center console is depressed. This feature has been provided for the safety of small children riding in the rear of the car.

Warning

Always remove the ignition key especially if children are left unattended in the car. Unsupervised use of power windows and sliding roof may cause serious injury.

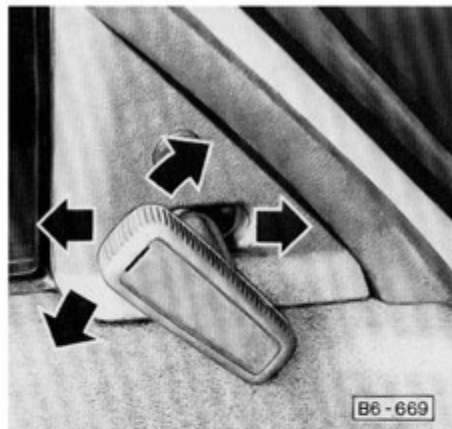

Outside mirror

Adjust the outside and inside mirrors before driving off. It is important for safe driving that you have good vision to the rear.

The mirror can be adjusted from the inside by moving the lever on the door panel.

Heated outside mirror

(Optional equipment)

When the rear window defogger/defroster is switched on (see page 32), the outside mirror is electrically heated at the same time.

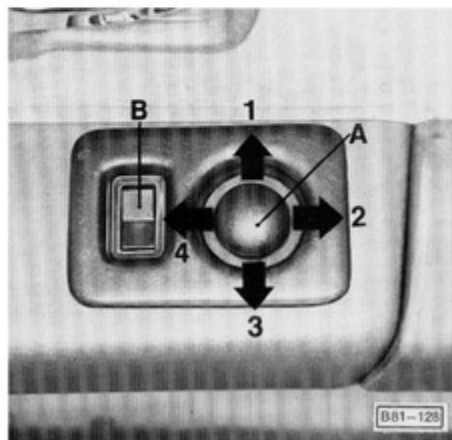

Outside mirror with electric remote control

(Optional equipment)

The remote control switches are located in the armrest of the driver's door. To adjust the outside mirror on the driver's side, depress rocker switch (A) as follows:

- | | |
|----------|-----------|
| 1 - left | 3 - right |
| 2 - up | 4 - down |

To adjust the outside mirror on the passenger's side, depress rocker switch (B).

In case an electric remote control mirror was installed just for the driver's convenience, there is only one rocker switch in the armrest.

When cleaning the outside mirror surface, use a mild soapwater solution only. Strong chemical or abrasive cleaning agents will damage or remove the mirror's non-glare coating.

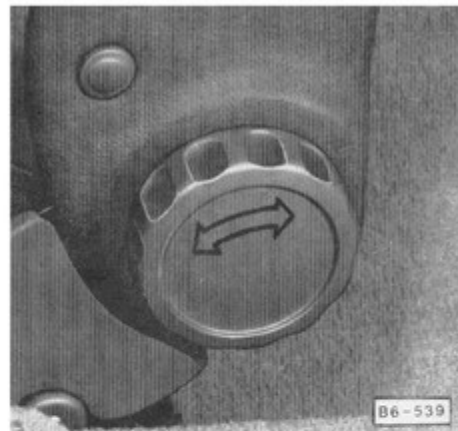
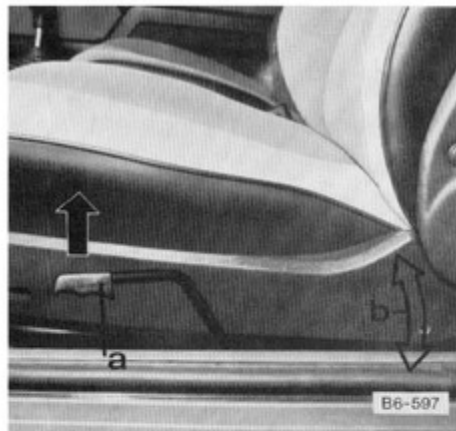
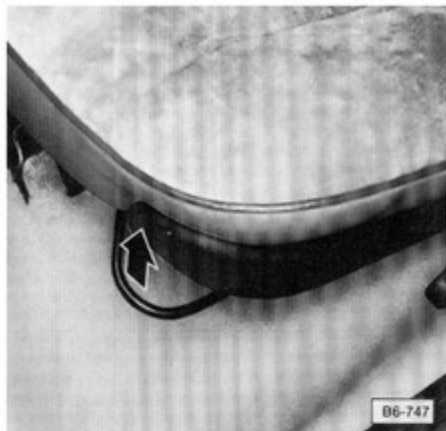

Seats

Do not adjust the driver's seat while driving. Your seat may suddenly jerk forward or backward, which could result in loss of control.

Front seat adjustment (forward or backward)

- Pull handle in front of seat.
- Slide seat to desired position.
- Let handle go, move seat slightly back and forth to make sure it is securely engaged.

Driver's seat with height adjustment

- Pull lever a and shift your body weight forwards or backwards to lower or raise the seat in position b.
- Release the lever to lock the seat at the desired height.

Do not adjust the height of the seat while the car is in motion.

Seatback adjustment

Reclining front seats

- Turn wheel at inboard side of seat cushion, with your body weight taken off the seatback.

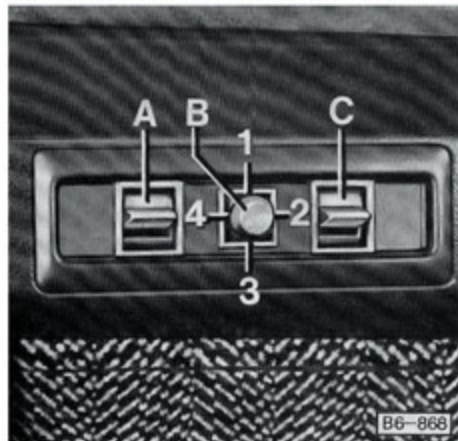

Electrical adjustable seats

(Optional equipment)

The two front bucket seats have a power adjustment for reach and height. The seat adjustment controls also work with the ignition off.

Switch A

Push switch up to raise rear of seat cushion. Press switch down to lower rear of seat cushion.

Lever B

Lever B adjusts both reach and height of the seat.

- Direction 1 = raises seat
- Direction 2 = moves seat forward
- Direction 3 = lowers seat
- Direction 4 = moves seat back

Switch C

Push switch up to raise front of seat cushion. Press switch down to lower front of seat cushion.



Electric heating for front seats

(Optional equipment)

When the ignition is switched on, the front seat backrests and the top of the seat cushions can be heated electrically.

The heating elements in the seats can be actuated by depressing switch in the dashboard panel. A light in the switch will glow as long as the heating elements are actuated. If heating elements are installed in both front seats they can only be switched on or off together.

For safety reasons and comfort the heating elements in the seats can only be switched on when the temperature on the surface of the seat is below about + 20°C/68°F. The heaters are switched off automatically when the seat temperature rises above + 40°C/104°F.

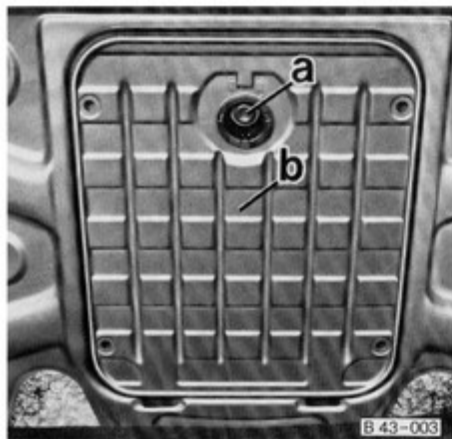

Ski sack

(Canada models only)

The ski sack allows you to transport skis or other long objects well protected inside the car.

To stow skis

- Open trunk lid and move all stored items to the sides to form a free path in center of luggage compartment floor.
- Press knob (a) in and lift up panel (b) to remove.
- Inside the vehicle, tilt center armrest in rear seat backrest down.
- Open and unhook the zipper.
- Pull ski sack (c) all the way out.
- From luggage compartment slide skis into the car's interior.

When returning the ski sack to its stowed position, be sure the fabric is dry to prevent mildew forming.

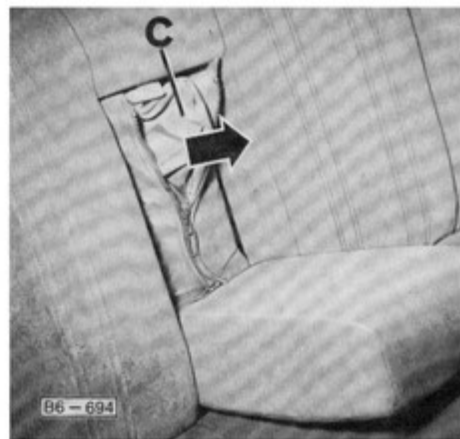

Center armrest

For easier handling of the ski sack, the center armrest can be removed.

- Press backrest bolsters sideways for access to holding hooks.
- Push holding hooks (arrow) toward rear and lift armrest up to remove.

When installing the armrest –

- Insert from above and press down into holding hooks
- Make sure both holding hooks are seated correctly.



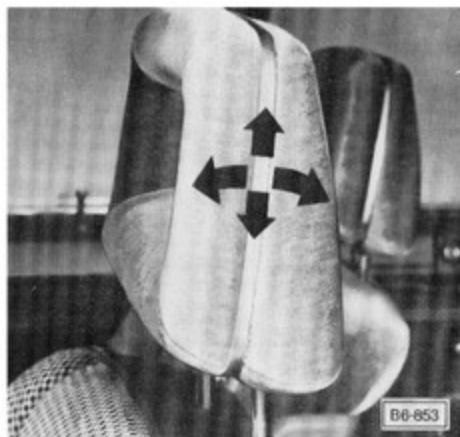

Head restraints

The padded head restraints of the front seats are adjustable.

- To tilt restraint forward or back, grasp firmly with both hands and move to the desired position.
- For height adjustment, grasp firmly with both hands and pull up or push down. Make sure the head restraint is securely seated in one of the three height guide slots.

Head restraints are designed to help reduce injuries. For maximum protection never drive the vehicle without head restraints.

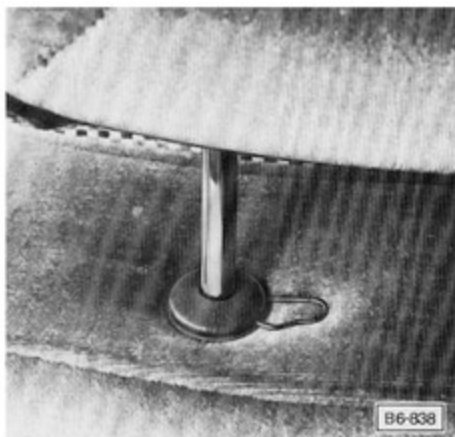

Removing and installing head restraints on front seats

Pry the spring clips out of the slotted guide rings in the backrest with a small screwdriver. Pull out head restraint. When reinstalling, first place head restraint in position and then press in spring clips so that the straight edge of each clip is at the front.

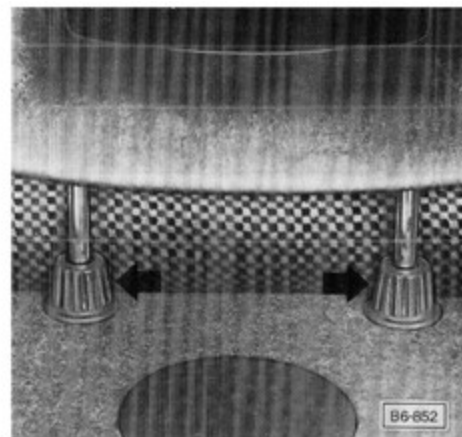

Removing and installing head restraints on rear seats (Optional equipment)

To remove: turn both retainer caps about 90° to the right or left and pull head restraint up.

To install: place head restraint into guides and turn retainer caps to lock head restraint in place.

For safety reasons try to lift head restraints out again to make sure that springs are securely engaged.

Safety belts

Lap/shoulder belts for front and rear seats

Belt warning system

An audio-visual warning system is interconnected with the driver's safety belt.

Every time the ignition is turned on, the safety belt warning light will come on for about 6 seconds as a reminder to buckle up. If the driver does not fasten the safety belt, the bell will also ring for the duration of this six second period. With the driver's door closed, the bell will go off as soon as the driver has buckled up.

Inertia reel retractor

The one-piece lap/shoulder belt with inertia reel locking mechanism adjusts automatically to your size and movements as long as the pull on the belt is slow.

Rapid deceleration during hard braking or a collision locks the belt. The belt will also lock when you drive up or down a steep hill or in a sharp curve.

To release a locked belt, lean back to take the body pressure off the belt.



- To **FASTEN**, grasp belt tongue and pull belt in continuous slow motion across your chest and lap.

- **Insert belt tongue into buckle on inboard side of seat. Push down until it is securely locked with an audible click.**

- **Pull shoulder section to make sure belt fits snugly across the hips.**

- **Belts should fit snugly across lap and chest. Make sure any slack is wound on the retractor.**

- **Do not wear shoulder part of belt under your arm or otherwise out of position. This would increase the possibility of serious injury in case of an accident.**

- To **UNFASTEN** belt, push in release marked **PRESS** on buckle. Belt will spring out of buckle.

- To **STORE** lap/shoulder belt, allow belt to wind up on retractor as you guide belt tongue to its stowed position.



Lap belt for rear seats

The automatic retractor will lock the rear seat lap belt as soon as your passenger has buckled up.

Note

The belt can only be pulled out when it is fully retracted.

- To **FASTEN** lap belt; grasp belt tongue and slowly pull across lap. Insert belt tongue into buckle and push down until it is securely locked with an audible click.

- To **UNFASTEN** belt, push in release marked **PRESS** in the buckle.

- To **STORE** belt, allow belt to wind up as you guide belt tongue to retractor.

Belt tongue and buckle should always be kept on top of seat for ready use.

- For your and your passenger's protection, use safety belts at all times while the car is in motion.
- Do not strap in more than one person with each belt.
- Belts should not be worn twisted.
- The lap belt portion should be worn low across the pelvic crest.
- Do not wear belts over rigid or breakable objects in or on your clothing, such as eye glasses, pens, keys, etc. as these may cause injury.
- Several layers of heavy clothing may interfere with proper positioning of belts.
- Belts must not rub against sharp objects.
- Keep belt buckles free of any obstruction that may prevent secure locking.
- Make sure the belt of the unoccupied passenger seat is fully wound up on its retractor so that the belt tongue is in its stowed position. This reduces the possibility of the tongue becoming a striking object in case of a sudden stop.

A shoulder belt should not be worn by a person less than 4'7" or 1.40 m in height, because it would not be in its most protective position, and therefore may increase the possibility of injury in a collision.

For a person between 4'7"/1.40 m and 5'7"/1.70 m in height, or with an erect seating height between 2'5"/74 cm and 2'11"/90 cm we recommend that the safety belt be fastened to the lower anchorage point on the doorpost.

Ask your Audi dealer to mount the belt on this point.

Persons smaller than 4'7"/or 1.40 m in height, and children who are able to sit upright by themselves, should use one of the rear seating positions and the lap belt provided.

Children who are not able to sit upright by themselves should use a child's seat.

The lap/shoulder belts should not be used to hold a child's seat as these belts will not provide the needed protection.

Belt care

- Belts that have been subjected to excessive stretch forces in an accident should be replaced (consult your dealer).
- If belts show damage to webbing, bindings, buckles or retractors, they should be replaced.
- If belts do not work properly, see your Audi dealer to have them repaired or replaced.
- Do not modify or disassemble the safety belts in your car.
- Keep belts clean. If they need cleaning, use a mild soap solution, but do not remove belts from car. DO NOT use other cleaning agents as they will weaken the webbing.
- NEVER bleach or dye safety belts.
- DO NOT allow safety belts to retract until they are completely dry.



Storage shelf

A covered storage shelf is located between the front bucket seats.

TO OPEN, grasp cut-out (arrow) and pull lid cover up.

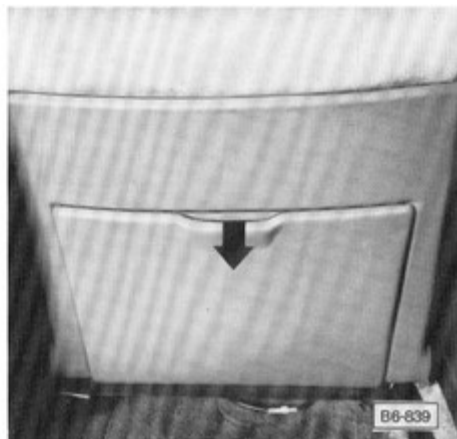

Storage pockets

The storage pockets are located on the backrests of the front seats.

TO OPEN, pull upper edge of pocket (arrow).

Instrument panel

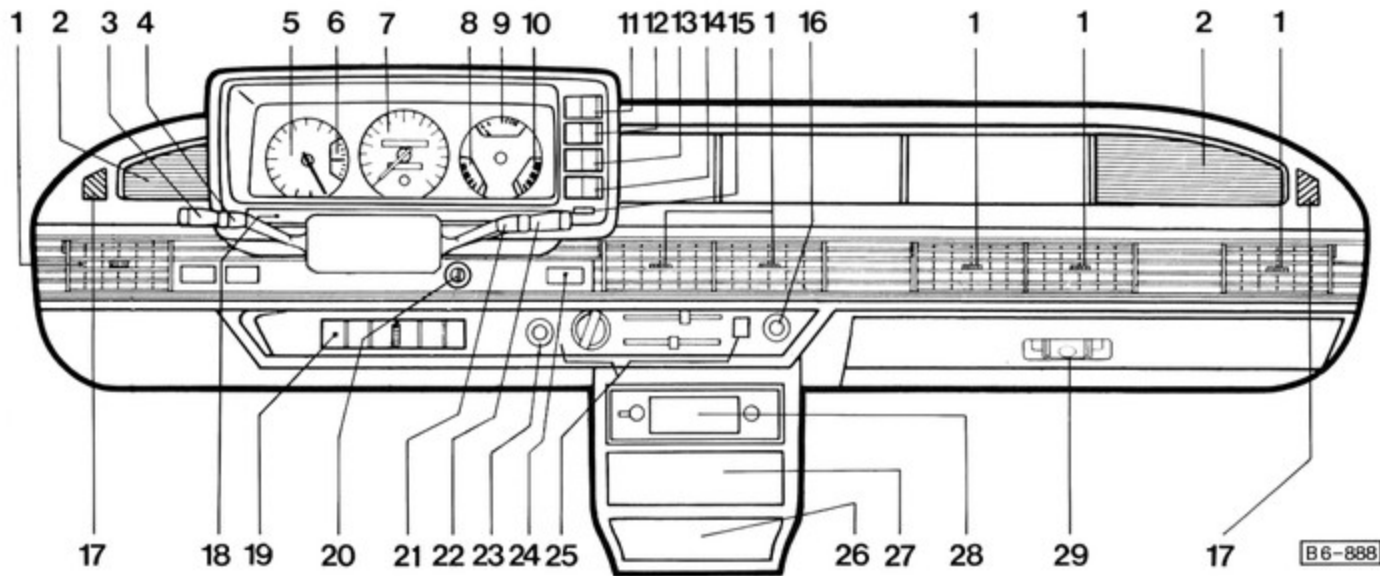

- 1 – Heater and fresh air outlets
- 2 – Loudspeaker grille
- 3 – Turn signal/headlight dimmer switch lever
- 4 – Light switch
- 5 – Tachometer
- 6 – Turbo boost pressure gauge
- 7 – Speedometer
- 8 – Water temperature gauge
- 9 – Oil temperature gauge
- 10 – Fuel gauge

- 11 – Rear window defogger switch
- 12 – Automatic cruise control master switch
- 13 – Not connected
- 14 – Switch for electrically heated front seats (optional equipment)
- 15 – Instrument illumination
- 16 – Cigarette lighter
- 17 – Defroster nozzles for side windows
- 18 – Warning/indicator control lights
- 19 – Fresh air outlet
- 20 – Ignition/steering lock

- 21 – Emergency flasher switch lever
- 22 – Windshield wiper/washer lever
- 23 – Balance control for radio (optional equipment)
- 24 – Not connected
- 25 – Climate controls
- 26 – Ashtray
- 27 – Storage shelf
- 28 – Radio* (optional equipment)
- 29 – Glove compartment (lockable)

Horn operation: Depress plate of steering wheel hub (not illustrated)

* For factory installed radio operating instructions are included

Ignition/steering lock

The steering is equipped with an antitheft ignition lock.

Important reminders before starting

Never start or let the engine run in an enclosed unventilated area. Exhaust fumes from the engine contain carbon monoxide which is a colorless and odorless gas. Carbon monoxide can be fatal if inhaled.

For your protection, fasten safety belts.

Automatic Transmission

- Move selector lever to Neutral or Park.

NEVER LEAVE ENGINE IDLING UNATTENDED. If warning lights should come on to indicate improper operation, they would go unheeded. This could result in severe damage to the car.

See **WARNINGS** on page 68.



Switch positions

- 1 – Ignition off/steering locked.
Insert the key. If it is difficult to turn the key, gently move the steering wheel until the key turns freely.
- 2 – Ignition on/steering free (for towing).
- 3 – Starter engages.
The key returns to position 2 as soon as it is released.

Do not operate starter continuously for more than 10 seconds. If engine fails to start, turn key back to pos. 1 and restart. Allow about 1 minute between each starting attempt. Also see “Starting procedure”.

www.audi-klassik.de

With key in position 2, the following warning lights come on:

- Alternator
- Oil pressure
- Oxygen Sensor (OXS)
- Water temperature light.

These lights should go out after the engine is started.

- Safety belts warning light will go out as soon as the driver has buckled up or after about 6 seconds.
- BRAKE light will go out after the engine is started and the parking brake fully released.

For more details see “Warning/indicator lights” on page 27.

Remove key and lock steering wheel

- Turn key back to pos. I and pull out. Turn steering wheel until it locks.

Only remove key after car has come to a standstill and parking brake is engaged.

Do not remove the key from the steering lock while the car is rolling to a stop. The steering column is locked as soon as you remove the key and turn the wheel slightly. Remove the key only after the car is parked.

Never let car roll by its own weight with transmission in Neutral. Such coasting may lead to sudden loss of control and damage to transmission and engine, when a gear has to be engaged.

Bell chime

If you leave the key in the ignition/steering lock, you will hear a bell chime when the driver's door is opened. This is your reminder to remove the key.

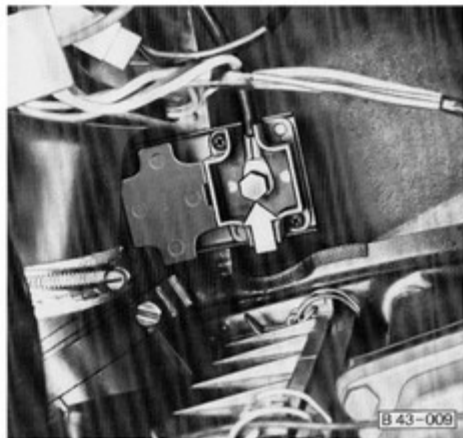

Emergency start assist:

For vehicles with factory-installed air conditioner and battery located under rear seat.

On the right side (as seen in driving direction) in the engine compartment, attached to the lower side member of the chassis frame is a small black plastic box.

Upon removing the box, you will see a positive (+) battery post (remote connection). Attach the positive (+) jumper cable clamp to this post for emergency starting.

Attach the negative (-) post to the ground of the engine block.

**"Emergency starting with jumper cables"
- see page 78.**

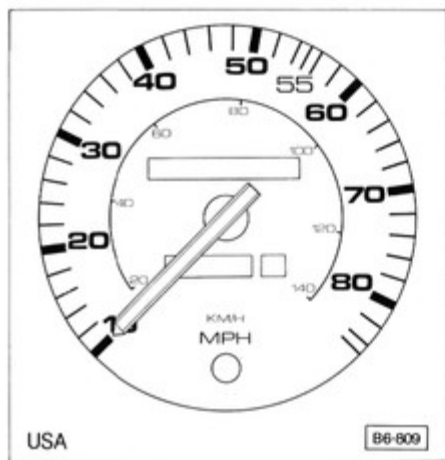

Instruments

Speedometer dial

The speedometer indicates the speed. The odometer indicates the distance driven.

U.S. models: Miles
 Canada models: Kilometers

Trip odometer

To record a distance, reset the trip odometer to zero by pressing the button. The last digit in red indicates $\frac{1}{10}$ of a mile (kilometers in Canada).



Turbo boost pressure gauge

The gauge in the right side of the tachometer indicates turbo boost pressure. The gauge is calibrated to read absolute pressure. When the engine is not running the gauge reads "1" which is normal atmospheric pressure. A reading of over "1" indicates boost pressure, while a reading of less than "1" indicates vacuum.

When driving at maximum power, the boost pressure can become too high. In this case, the fuel pump will shut off automatically and the engine will stop running. As soon as the boost pressure returns to normal the fuel pump will resume operation and you can continue to drive.

In case of repeated excessive boost pressures, have your Audi Dealer locate and remedy the cause promptly.

Tachometer

The checkered area at the end of the scale indicates the maximum permissible engine rpm (revolutions per minute) for all gears. Before reaching this area, ease up on the gas pedal.

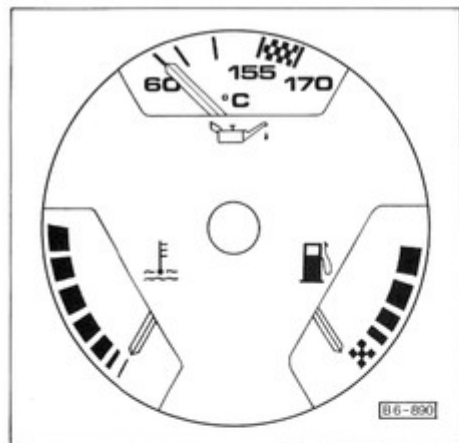

Combination instrument

Fuel gauge

(Only works with the ignition on)

The needle in the fuel gauge will indicate the fuel level in the tank shortly after the engine is running.

When the needle enters the red area, there is a reserve of about 2.0 U.S. gal./7.5 liters of fuel left in the tank. Time to refuel.

Water temperature gauge

(Only works with the ignition on)

The needle in the water temperature gauge will indicate the temperature of the coolant shortly after the engine is running.

Engine operating temperature will vary with climate, traffic conditions and engine load. Maintain moderate speed until the engine has warmed up.

Needle in lower field – engine is cold.
Avoid high speeds and excessive engine rpm. Do not lug the engine.

Needle in center field – normal.
Engine at normal operating temperature.

Needle in upper field and the water temperature warning light (see page 28) flashes on – engine is too hot.

If the needle reaches the upper field and the water temperature light flashes on, pull off the road and stop the engine. Wait until radiator and engine have cooled down before checking the coolant level and the V-belt tension.

WARNING

Let the engine cool down. Hot components can burn skin on contact. The fan switches on automatically when the coolant reaches a certain temperature and continues to run (even with engine stopped) until the coolant temperature drops.

Therefore, never touch the fan blades as they will rotate spontaneously when the thermostat turns the fan on.

Check coolant level and V-belt tension. If both are correct, but needle remains in upper field and the water temperature light stays on, contact your nearest dealer to have the cause located and corrected.

For more details see “Cooling system”.

The air conditioner (where applicable) should be switched off when engine tends to overheat.

Oil temperature gauge

Engine oil temperature is measured in degrees Celsius from 60°C (140°F) to 170°C (338°F). With needle around 60°C (140°F), do not accelerate under full load.

Reduce speed if needle reaches red zone.

If temperature does not drop, pull safely off the road. Turn the engine off and wait for it to cool down.

Check oil and coolant levels (see “Engine oil checking” and “Cooling system”).

If both levels are normal, contact your nearest dealer.

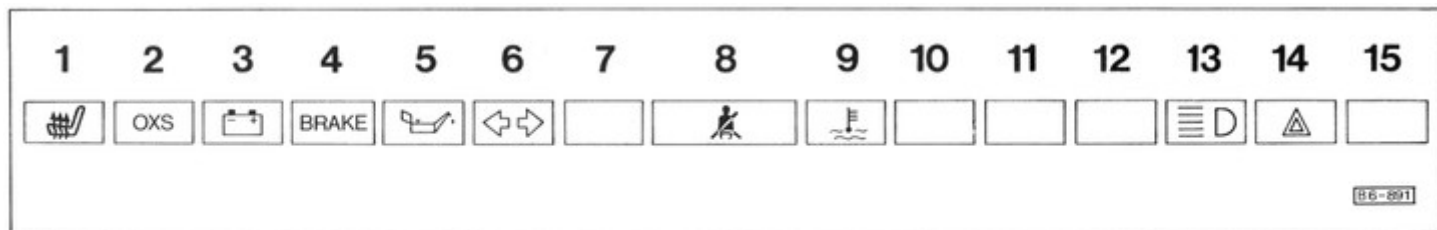

Warning/indicator lights

Whenever stalled or stopped for repair, move the car well off the road. Turn on the emergency flasher and mark the car with flares or other warning devices.

WARNING

Before you check anything in the engine compartment, let the engine cool down. Hot components can burn skin on contact.

The fan switches on automatically when the coolant reaches a certain temperature and continues to run even with engine stopped until the coolant temperature drops. Therefore never touch the fan blades as they will rotate spontaneously when the thermostat turns the fan on.

1 – Electric seat heating light

See page 15.

2 – Oxygen Sensor Light OXS

(where applicable) The OXS indicator light **COMES ON** when the ignition is turned on and **GOES OUT** after the engine is started.

The OXS light functions as a “**Service Reminder**”. The light **COMES ON AND STAYS ON** every 30,000 miles or 48,000 km to remind you to take your car to your Audi dealer for the scheduled emission control maintenance service.

3 – Alternator warning light

COMES ON when the ignition is turned on and **GOES OUT** after the engine is started.

If the alternator **WARNING LIGHT DOES NOT LIGHT UP** when turning the ignition on or **DOES NOT GO OUT** after starting the engine, there may be a malfunction in the electrical system. In this case, contact your Audi dealer.

Pull off the road and **stop at once** if the alternator warning light comes on while driving! Continued driving can cause severe engine damage.

Turn the engine off!

Check first whether the V-belt is slipping or broken. V-belt should be tightened or replaced. See “V-belt tension checking” on page 73.

4 – BRAKE warning light

COMES ON while the engine is cranking. It should GO OUT after the engine is started and the parking brake fully released. This is your assurance that the brake warning light functions properly.

If the brake warning light DOES NOT LIGHT UP while cranking the engine or setting the handbrake, there may be a malfunction in the electrical system. In this case, contact your Audi dealer. If the brake warning light LIGHTS UP with the engine running and the parking brake fully released, the fluid level in the brake fluid reservoir may be too low. This might be due to a leak in one of the two independently working brake circuits.

For further details refer to “Functioning of brake system” on page 45.

5 – OIL pressure warning light

COMES ON when the ignition is turned on and GOES OUT after the engine is started.

If the oil pressure warning light DOES NOT LIGHT UP when turning the ignition on or if it DOES NOT GO OUT after starting the engine, there may be a malfunction in the electrical system. Contact your Audi dealer promptly to have the cause located and corrected. To be sure of sufficient engine oil pressure, briefly depress the accelerator pedal and raise the engine speed to medium engine rpm (above 2000). The oil pressure warning light will not come on if engine oil pressure is normal. If the light lights up while driving, a buzzer sounds simultaneously. This indicates that the oil pressure is too low.

Check the engine oil level, add oil if necessary. If engine oil level is normal, but the buzzer sounds and the light continues to light while the engine speed is above 2000 rpm, do not continue to operate the vehicle. Remember that the warning light will not come on when the engine is idling.

Turn the engine off and contact the nearest Audi dealer for assistance.

Note:

The oil pressure warning light is not an indicator for low engine oil level. To check the oil level, always use dipstick (see page 69).

6 – Turn signal light

For details see “Turn signal/headlight dimmer switch lever” on page 30.

7 – Not connected

8 – Safety belt warning light

Every time the ignition is turned on, the seat belt warning light COMES ON for about 6 seconds as a reminder to buckle up.

9 – Water temperature warning light

COMES ON when the ignition is turned on and GOES OUT after the engine is started.

If the water temperature warning light flashes on while driving, the engine may be overheated. Pull off the road, stop the engine and lift lever up for emergency flasher.

For more details see “Water temperature gauge” on page 26.

Do not install accessories (fog lights or insect screens, for example) on top of the front bumper. They may interfere with sufficient cooling of the engine.

10 – Not connected.

11 – Not connected.

12 – Not connected.

13 – High beam indicator light

COMES ON when high beams are on.

14 – Emergency flasher light HAZARD

The warning light flashes after operating the short lever on right side of the steering column to make all four turn signals flash simultaneously.

Move the car well off the road when stalled or stopped for repairs.

15 – Not connected.

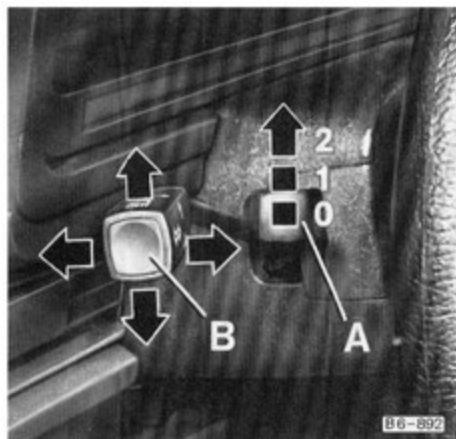

A – Light switch

(short lever on left side of steering column)

Switch positions:

- 0 – all lights off
- 1 – all lights on, except headlights
- 2 – headlights and all other lights on (with ignition on)

To conserve battery power, the headlights will go out automatically when the ignition is turned off or when the engine is started.

B – Turn signal/headlight dimmer and flasher switch lever

(long lever on left side of steering column)

Turn signals

- Lever up – right turn signals
- Lever down – left turn signals

The turn signal indicator light flashes when you operate the lever.

The turn signals are cancelled automatically when you have completed a turn (like driving around a corner) and the steering wheel returns to the straight-ahead position.

If a turn signal fails, the indicator light flashes about twice as fast. A light bulb may have to be replaced.

Lane changer

To indicate your intention when changing lanes on expressways, slightly move the lever up or down just to the point of resistance. The lever will return to the OFF position when released.

Headlight dimmer and flasher

(with headlights on - short lever in Pos. 2)

Dim or flash headlights by operating long lever.

- Low beam – lever in center position
- High beam – lever pushed forward
- Flashing – lever pulled toward steering wheel

When high beams are on, the blue indicator light lights up.

Headlight flasher

You can signal with your headlights (in lieu of horn) during daylight, by repeatedly pulling and releasing the lever just to the point of resistance.

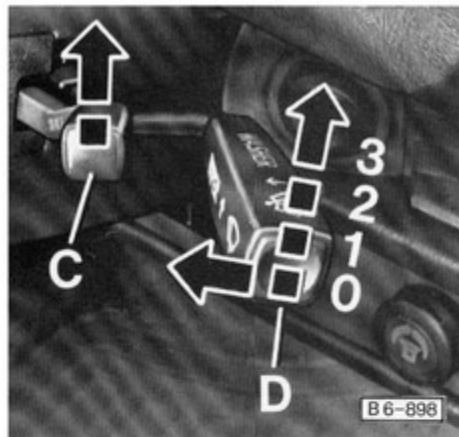

Move the car well off the road when stalled or stopped for repairs. Do not remain in the car.

Do not park or operate the car in areas where the hot exhaust system may come in contact with dry grass, brush, fuel spill or other flammable material.

C – Emergency flasher switch

(short lever on right side of steering column)

The emergency flasher works independently of the ignition switch positions.

If your car is disabled or parked under emergency conditions, lift lever up to make all four turn signals flash simultaneously. The light in the instrument panel flashes at the same frequency.

Lever up – hazard light on
Lever down – hazard light off

D – Windshield wiper/washer lever

(short lever on right side of steering column)

Windshield wipers WIPE

The windshield wipers can be operated at the following speeds:

- 0 – off
- 1 – intermittent
- 2 – low speed
- 3 – high speed

In position 1 (intermittent wiping) the wipers sweep the windshield approximately every 5 seconds.

They only work with ignition on.

www.audi-klassik.de

Lifting the lever slightly without engaging the first stop allows the wipers to operate for as long as the lever is held in this position. The lever will return to the OFF position when released.

Avoid running the wipers over a dry windshield to prevent scratching the glass. Spray washer fluid on first.

Check the wiper blades periodically. Worn or dirty blades reduce visibility, making driving hazardous. Free blades frozen to glass before operating wipers.

Windshield washer WASH

To spray washer fluid on the windshield, pull the lever toward the steering wheel from any selected wiping position.

If you pull the lever from the 0-position, washer fluid is sprayed on the windshield and the wipers work. When lever is released washer stops immediately, but wipers will continue to run several times to dry the windshield.

Clean all windows, windshield and wiper blades regularly to remove road film and car-wash wax buildup. Use an alcohol base cleaning solution and a sponge or soft cloth. Dry glass with a chamois.

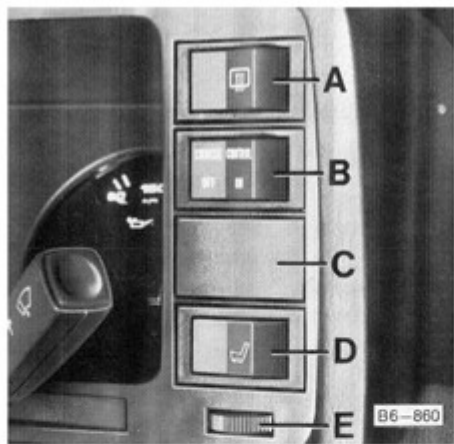

A – Rear window defogger

The rear window defogger only works with the ignition on.

The rear window defogger – together with the flow through ventilation – will help to keep the rear window clear of condensation and frost in the winter.

Depress the switch to turn on the rear window defogger.

The control light in the switch will light up to remind you that the defogger is switched on. After the rear window has been cleared, switch off the rear window defogger to avoid an unnecessary drain on the battery.

The filler panel between the rear seat and the rear window should not be used for storage, even for small and light items. During sudden stops, these articles may cause injury when dislodged. Larger items may also reduce vision to the rear.

B – Automatic cruise control master switch

The master switch with the ON/OFF positions supplies the system with **electric power**. See “Automatic cruise control” on page 38 for details.

C – Not connected

D – Front seat heating switch (Optional equipment)

When the ignition is switched on, the front seats can be heated electrically by depressing this switch. See “Electric heating for front seats” on page 15 for details.

E – Instrument illumination

Turn the thumbwheel to adjust the brightness of the instrument panel lights.



Inside day-night mirror

Adjust the outside and inside mirrors before driving off. It is important for safe driving that you have good vision to the rear.

You can adjust the day-night mirror from clear daylight visibility to non-glare visibility at night by moving the lever at the bottom of the mirror:

Daylight driving – lever forward
Night driving – lever down

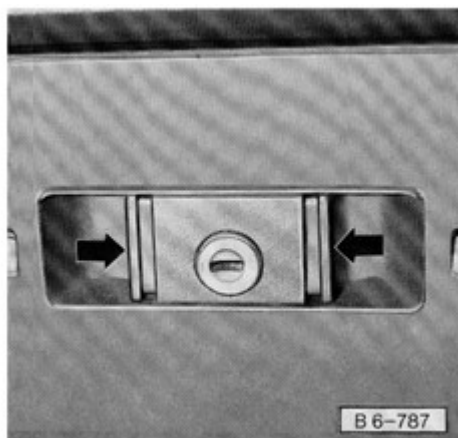

Glove compartment

(Lockable and illuminated)

To open

– Squeeze the two lock latches together (arrows).

To close

– Press door upward until lock engages.

To lock or unlock

– Turn master key to right or left.

The light will come on when the glove compartment is opened. With the door closed, the light will be off.

Keep glove compartment door closed while driving to prevent injury during a collision.

Sun visors

To protect driver and passenger from side glare, each sun visor can be moved toward the door window after lifting it out of its center mounting.

A vanity mirror is on the back of the sun visor on the passenger's side.

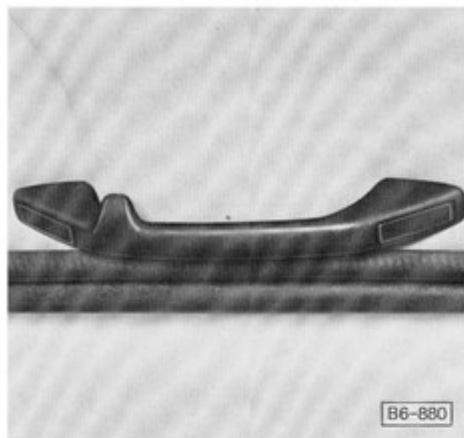

Assist handles and coat hooks

There are three assist handles above the door frames: one for the front passenger and two for the rear seat passengers.

Each rear seat assist handle includes a coat hook.

Hang clothes in such a way that they do not impair the driver's vision.

Do not hang heavy objects on the coat hooks, as they could become striking objects in the event of a sudden stop.

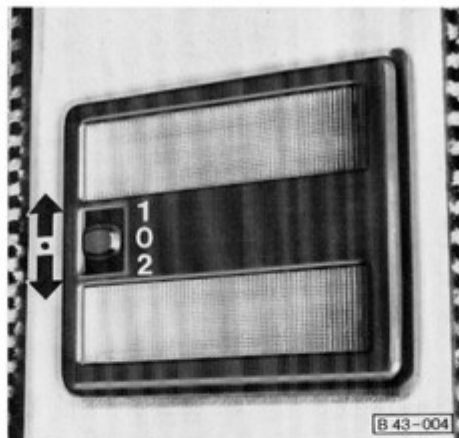

Interior dome light

The three switch positions are:

Backward (2) – ON (with front doors open)
 Center (0) – OFF
 Forward (1) – ON (continuously)



Interior light

(On cars with electric sun roof)

The three switch positions are:

Up (1) – ON (with front doors open)
 Center (0) – OFF
 Down (2) – ON (continuously)



Cigarette lighter

- Push knob in.
When lighter is ready for use, it will spring back.

The socket of the cigarette lighter may be used for 12 volt appliances with maximum consumption of up to 200 watts, such as hand spot light, small vacuum cleaner, etc.

Rear

The cigarette lighters in the rear doors can only be used if the safety switch (S) in the center console is depressed (see page 12).

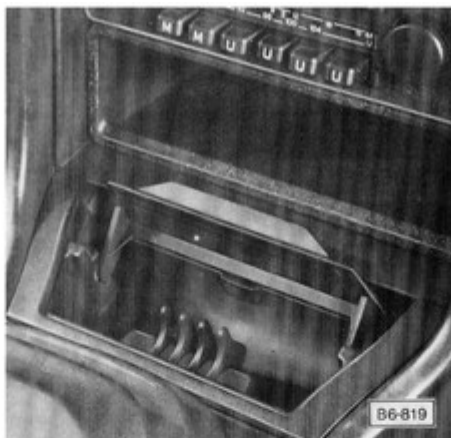

Ashtrays

Front

- To empty, lift out tray.
- Reinstall by pressing tray into housing.

WARNING:

Never use ashtrays as waste paper receptacles . . . fire hazard!

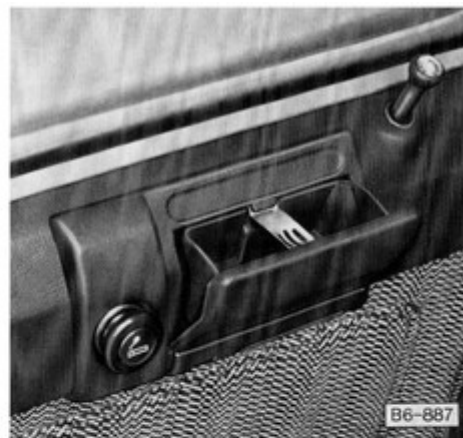

Rear

- To remove, press tray down and lift out.
- To put tray back in, insert lower part first. Tilt upper part forward until tray engages.

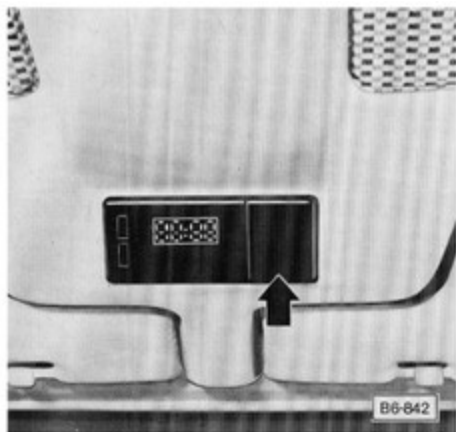

Clock

When the ignition is on, the digital numerals are illuminated. When the ignition is off, depress switch on the right side (arrow) for illumination.

To set the clock, depress switches on the left side:
the upper for the hours,
the lower for the minutes.

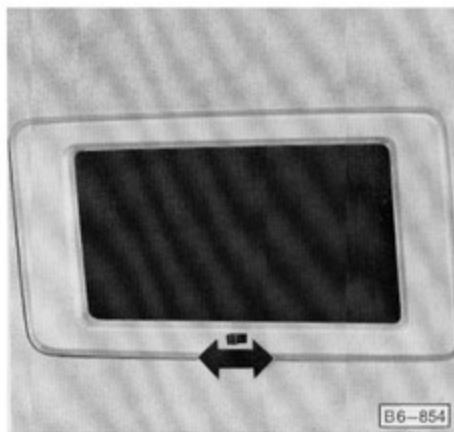

Vanity mirror

(optional equipment)

A vanity mirror is located on the back of the sun visor on the passenger's side.

To illuminate the vanity mirror, slide the switch.

When the sun visor is tilted up, illumination is shut off automatically.



Reading lights

There are reading lights in the front passenger's door and in the two rear doors below the ashtrays.

Press the switch (arrow) to turn lights on or off.

Sliding roof

(Optional equipment)

The electrically operated sliding roof can be opened fully, or it can also be raised at the rear only.

The sliding roof operates only when the ignition is on.

To open and close sliding roof

- To open, depress side **B** of rocker switch. Release switch when sunroof is in desired position.
- To close, depress side **A** of rocker switch until roof is completely closed.

To raise sliding roof at rear

Sunroof should be closed.

- Depress side **A** of rocker switch until rear is raised to desired position.

To lower sliding roof at rear

- Depress side **B** of rocker switch until rear of sunroof is completely closed.

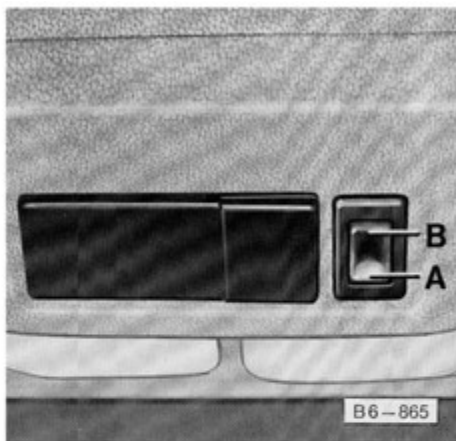

If sunroof is open and you wish to raise the rear portion of the roof only, you have to close the sunroof first by depressing side **A** of rocker switch.

- Release the switch, then press again on side **A** of rocker switch to raise the rear only.
- If the roof is up at the rear, and you wish to slide the front open, lower the rear first by depressing side **B** of rocker switch.
- Release switch, then press side **B** again to slide the roof to the desired position.

Manual operation

If the electric drive mechanism should fail, the sunroof can also be opened and closed manually with a crank provided for this purpose.

- Remove switch cover by pulling out of clip.
- Disconnect plug from switch and set aside.
- Turn back release lever below drive mechanism in direction of arrow.
- Take manual crank out of cover and insert in socket in shaft below drive mechanism.
- Turn crank in desired direction.

Wind deflector

The wind deflector, which comes up when the sunroof is opened, retracts automatically as the sunroof is being closed.

WARNING

Always remove your ignition key, especially if children are left unattended in the car. Unsupervised use of power windows and sliding roof may cause serious injury.

Automatic cruise control

The automatic cruise control allows you to maintain a constant cruising speed travelling above 22 mph or 35 km/h, without actuating the accelerator pedal.



Master switch

The master switch with the ON/OFF positions is for supplying the system with electric power.

WARNING

Do not use the cruise control when driving on winding or slippery roads, or in stop and go traffic.

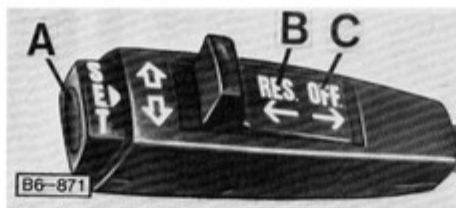

Operate the cruise control with the switches
SET – RESUME – OFF

A – SET

Accelerate to the desired speed above 22 mph or 35 km/h and depress **SET** switch. When this switch is pressed down the vehicle continues to accelerate until the control is released. This sets the cruising speed and stores it in a memory. After a second or two, the automatic speed control will take over, and you can remove your foot from the accelerator pedal. The set cruising speed will be maintained automatically without actuating the accelerator pedal.

If you accelerate – for example when passing a car – the previously programmed speed will be resumed automatically after the accelerator pedal is released.

B – RESUME

The automatic cruise control is temporarily disengaged when brake pedal is depressed or when the road speed drops considerably below programmed speed.

To re-engage the system, switch to **RESUME**, and the car will automatically accelerate to the previously set speed.

C – OFF

Moving the switch to the **OFF** position temporarily disengages the system. Move to **RESUME** to return to the previously set speed. However, a programmed speed is completely erased from the memory of the cruise control system when the ignition is turned off or the current is turned off with the master switch on the dashboard.

Important reminders

When the cruise control is switched on, do not shift into Neutral without declutching! The engine will rev up immediately and may be damaged.

If engine power is not sufficient to maintain the present speed, for example when driving uphill, the cruise control is automatically disengaged when the road speed drops considerably below the programmed speed.

Any manual operation, such as accelerating, gearshifting or braking can be done independently of the automatic cruise control.

If the accelerator linkage should stick or jam completely, your possibilities of controlling the engine speed will be limited. In this event: Switch off the cruise control with the master switch and call your nearest Audi dealer for assistance.

DO NOT REMOVE KEY FROM STEERING LOCK while you are driving or while the car is rolling to a stop. The steering column is locked when you remove the key, and you will not be able to steer the car.

Luggage compartment

When transporting luggage or other cargo, secure it in place. This precaution will help prevent such articles from shifting during a sudden stop.

Keep the luggage compartment lid closed while driving to prevent exhaust fumes from being drawn into the car.

Because of inherent hazards, we do not recommend transporting objects larger than those that can safely be fitted into the luggage compartment.

Keep the luggage compartment lid locked at all times! With lock slot in the horizontal position, the lid can be opened without key.



- **UNLOCK** by turning key to the left.

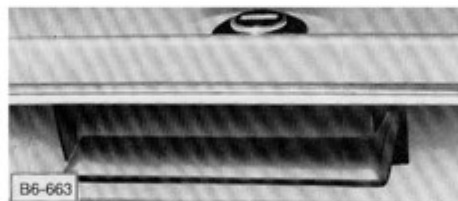

- **PULL** lever under lid and lift lid.
- Raise lid until it is held in the fully open position.
- To **CLOSE**, swing lid down firmly.
- Lock with key.

Central locking system

Luggage compartment lid key slot turned to horizontal position (unlocked)

Luggage compartment lid can be locked and unlocked by central locking system (see page 11).

To open only luggage compartment lid with actuated central locking system.

Turn master key in the luggage compartment lid slot to right as far as it will go. Pull the lever under lid and lift lid.

Key slot in vertical position (locked)

Luggage compartment lid remains locked when actuating central locking system. This provision has been made to facilitate permanent locking of the luggage compartment lid when leaving your car in a public garage or workshop. Take master key with you and leave ignition/door key with attendant.

While master key is for all locks, the secondary key is for ignition switch, the lockable tank flap and door locks only.



Engine hood

Releasing the hood

- Unlock engine hood by pulling release handle on left under dashboard. Hood will pop up under spring pressure.

Opening the hood

- In front of car, open hood by moving safety hook to right (arrow).
- Raise hood until it is held in fully open position.

Closing the hood

- Pull hood down until it is locked.
- Try to pull up hood to check that it is securely latched.

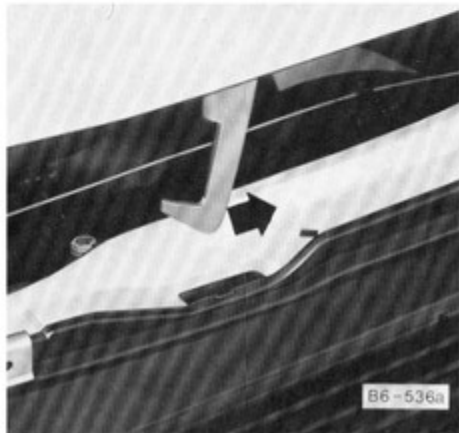

Starting procedures

Fasten safety belts!

Never start or let the engine run in an enclosed, unventilated area. Exhaust fumes from the engine contain carbon monoxide, which is a colorless and odorless gas. Carbon monoxide can be fatal if inhaled.

Automatic Transmission

- Start with selector lever in Neutral or Park.

Starting engine

- Always depress accelerator pedal slightly when starting. This applies at any outside temperature.
- As soon as the engine starts, release the ignition key.
- If the engine does not start the first time or stalls, turn the ignition off and restart.
- Operate the starter for 10 to 15 seconds only.
- Allow about 1 minute between each starting attempt.

When the ignition is turned on, several warning lights in the instrument panel will come on for a bulb check. They should go out shortly after the engine is started. See page 22 and "Warning/indicator lights" for details.

NEVER LEAVE CAR WITH ENGINE IDLING.

When starting engine, be ready to drive off immediately. Maintain moderate speed until engine is warm. If you leave engine idling unattended, warning lights that may come on to indicate improper operation would go unheeded. This could result in severe damage to the car.

Do not park or operate the car in areas where the hot exhaust system may come in contact with dry grass, brush, fuel spill or other flammable material.

"Emergency start assist" – see page 23.

"Emergency starting with jumper cables" – see page 78.

Stopping engine

Do not stop engine immediately after hard or extended driving. **Keep engine running at increased idle for about two minutes to prevent excessive heat build-up before turning off engine.**

WARNINGS

Before you check anything in the engine compartment, let the engine cool down. Hot components can burn skin on contact.

The fan switches on automatically when the coolant reaches a certain temperature and continues to run (even with engine stopped) until the coolant temperature drops. Therefore, never touch the fan blades as they will rotate spontaneously when the thermostat turns the fan on.

Fuel supply

UNLEADED FUEL ONLY

All Turbo gasoline engine models are equipped with a catalytic converter “Unleaded fuel” reminder stickers are located on the dashboard and on the inside of the fuel tank flap.

Cars with catalytic converter have a **smaller fuel tank opening, and gas station pumps have smaller nozzles**. This will prevent accidental pumping of leaded fuel into cars with catalytic converter.

The catalytic converter is an efficient “clean-up” device built into the exhaust system of your Audi. The catalytic converter burns the undesirable pollutants in the exhaust gas before it is released into the atmosphere.

Deposits from leaded gasolines destroy the catalytic converter and thus defeat its purpose to control harmful exhaust emissions.

Unleaded fuels may not be available outside the continental U.S. and Canada. Therefore, we recommend you do not take your car to areas or countries where unleaded fuel may not be available.

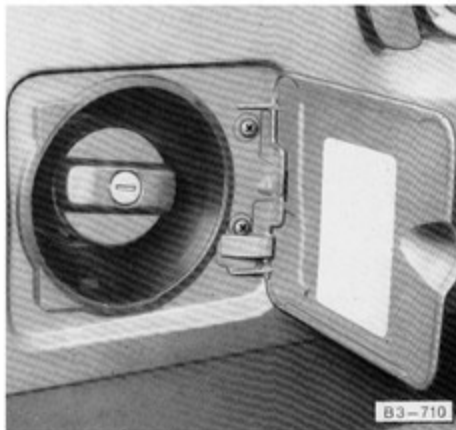

Fuel filler neck is on right rear side panel of car. When putting cap back on, twist it clockwise to its stop.

Fuel tank capacity is listed under “Technical Data/Capacities”.

Never start or let the engine run in an enclosed unventilated area. Exhaust fumes from the engine contain carbon monoxide which is a colorless and odorless gas. Carbon monoxide can be fatal if inhaled.

GASOHOL

A mixture of unleaded gasoline and ethanol (ethylalcohol) known as “Gasohol” is available in gas stations in some areas.

Audi vehicles are designed and certified to use gasoline as specified under “fuel supply”. You may decide to use gasohol in your Audi provided it contains not more than 10% ethanol and the octane requirements for your car are met.

However, we strongly recommend to switch back to gasoline without ethanol, if you experience the following adverse effects on your vehicle because of the use of gasohol.

- Deterioration of driveability and performance
- Substantially reduced fuel economy
- Generation of vapor lock and hot start problems, especially at high altitude or at high temperatures
- Engine malfunction or stalling.

The continued use of gasohol under these conditions may adversely affect the emission control system of your vehicle.

Engine exhaust is dangerous if inhaled. Therefore:

- Never start or let the engine run in a closed garage.
- Exhaust fumes from the engine contain carbon monoxide, which is a colorless and odorless gas. Carbon monoxide can be fatal if inhaled.
- Keep the luggage compartment lid closed while driving to prevent exhaust gas from being drawn into the car.
- Because of inherent hazards, we do not recommend transporting objects larger than those that can be fitted safely into the luggage compartment.
- Never carry additional fuel in portable containers in your car. Such containers, full or partially empty, may leak, cause an explosion, or result in fire in case of a collision.
- If you smell gas fumes in the car, drive with the windows open. Have the cause immediately located and corrected.

How you drive is what you get in fuel mileage

We made great efforts to make your car fuel efficient. However fuel economy will vary depending on where, when and how you drive, on the optional equipment installed in your car, and the condition of your car.

- Keep a light foot on the accelerator.
- Drive smoothly, avoid abrupt changes in speed as much as possible.
- Avoid jack rabbit starts and sudden stops.
- Do not drive longer than necessary in the lower gears. Changing up early helps to save fuel.
- Avoid unnecessary idling. Turn the engine off.
- "Warm up" idling wastes gas. Start the car just before you are ready to drive. Accelerate slowly and smoothly.
- Any additional weight carried in the car reduces fuel economy. Always keep cargo to a minimum and remove all unnecessary items.
- Organize your trips to take in several errands.
- Use air conditioner only when needed.

How to improve fuel mileage

A well tuned and properly maintained car will help you get maximum fuel economy.

- Have your car tuned to specifications.
- Fuel injection should be adjusted to specifications.
- Spark plugs should be clean, properly gapped and firing efficiently.
- Air cleaner should be dirtfree to allow proper engine "breathing".
- Battery should be fully charged.
- Wheels should be properly aligned.
- Tires should be inflated at correct pressures.
- **The published EPA mileage estimates may vary, depending on speed, weather and trip length. Your actual highway mileage will probably be less.**

Brakes

Functioning of brake system

Your Audi is equipped with a power assisted hydraulic dual circuit brake system with disc brakes at the front and rear. Both circuits function independently. Each brake circuit operates one front and rear wheel diagonally. This design, together with other front axle features, also helps to keep you on a straight course when braking.

In the unlikely event of hydraulic failure of one circuit, **push the brake pedal down firmly and hold it in that position.** A mechanical linkage activates the second circuit, and you will be able to bring the car to a safe stop.

Failure of one brake circuit will impair the braking capacity resulting in an increased stopping distance.

If one brake circuit has failed, the other will still operate. However, you will notice an increased pedal travel when you step on the brake. Should you encounter such experience, bring your vehicle safely to a full stop.

Avoid driving the car and have it towed to the nearest Audi dealer or qualified workshop.

Brake pedal

Do not “ride the brakes” by resting your foot on the pedal when not intending to brake. Overheating and wear of the brakes is the result.

The movement of the brake pedal must never be obstructed by a floor mat or any other object. In case one of the two brake circuits fails, increased pedal travel is required to bring your vehicle to a full stop.

Make sure that the size of your floor mat does not hamper the movements of either brake, clutch or accelerator pedals in any way.

Secure the floor mat against sliding into positions that could interfere with the safe operation of your vehicle.

Brake operation and brake warning light

Make it a habit to check the operation of your brakes before driving. The brake warning light will light up if the parking brake is not fully released and/or the brake fluid level is too low. See also “Brake warning light” for details.

Keep in mind that the braking distance increases very rapidly as the speed increases. At 60 mph or 100 km/h, for example, it is not twice but four times longer than at 30 mph or 50 km/h. Tire traction is also less effective when the roads are wet and slippery. Therefore, always maintain a safe distance.

Moisture or road salt on brakes can affect braking distance

Driving through water may reduce tire traction. Moisture on brakes from road water, car wash or coating of road salt may affect braking efficiency. Cautiously apply brakes for a test. Brakes will dry and salt coating will be cleaned off after a few cautious brake applications.

Brake wear

Audi automobiles have excellent brakes, but they are still subject to wear, depending on how the brakes are used. Have the brake system inspected at the intervals recommended in your Maintenance Schedule.

New brake pads or linings

Brake pads may not have the highest possible braking efficiency when new. Therefore allow for longer braking distance during the initial 100 to 150 miles or 150 to 250 kilometers.

Brake booster

The brake booster assists braking only when the engine is running. When the car is moving while the engine is not running, more force on the brake pedal is required to bring the car to a stop.

Accelerator pedal

For good fuel economy we recommend smooth and even acceleration. Very fast, racy driving, alternating between full throttle and hard braking, raises the fuel consumption considerably. Also, tires and brake linings wear faster. It is more economical to drive smoothly and at fairly constant speed.



Parking brake lever

Use the parking brake after the car has come to a full stop.

The parking brake lever is between the front seats.

To set the parking brake, pull the lever all the way up.

With the ignition on, the brake warning light will light up.

To release the parking brake, pull the lever slightly up, depress the release button (arrow), and then push the lever all the way down.

When the parking brake is fully released, the brake warning light goes out (see page 28 for more details).

- Release the parking brake fully. A partially engaged brake will overheat the rear brakes, reduce their effectiveness and cause excessive wear.
- Always set the parking brake when parking your car. Move the selector lever to "P".
- On hills also turn the wheels toward the curb.

Brakes

Functioning of brake system

Your Audi is equipped with a power assisted hydraulic dual circuit brake system with disc brakes at the front and rear. Both circuits function independently. Each brake circuit operates one front and rear wheel diagonally. This design, together with other front axle features, also helps to keep you on a straight course when braking.

In the unlikely event of hydraulic failure of one circuit, **push the brake pedal down firmly and hold it in that position.** A mechanical linkage activates the second circuit, and you will be able to bring the car to a safe stop.

Failure of one brake circuit will impair the braking capacity resulting in an increased stopping distance.

If one brake circuit has failed, the other will still operate. However, you will notice an increased pedal travel when you step on the brake. Should you encounter such experience, bring your vehicle safely to a full stop.

Avoid driving the car and have it towed to the nearest Audi dealer or qualified workshop.

Brake pedal

Do not "ride the brakes" by resting your foot on the pedal when not intending to brake. Overheating and wear of the brakes is the result.

The movement of the brake pedal must never be obstructed by a floor mat or any other object. In case one of the two brake circuits fails, increased pedal travel is required to bring your vehicle to a full stop.

Make sure that the size of your floor mat does not hamper the movements of either brake, clutch or accelerator pedals in any way.

Secure the floor mat against sliding into positions that could interfere with the safe operation of your vehicle.

Brake operation and brake warning light

Make it a habit to check the operation of your brakes before driving. The brake warning light will light up if the parking brake is not fully released and/or the brake fluid level is too low. See also "Brake warning light" for details.

Keep in mind that the braking distance increases very rapidly as the speed increases. At 60 mph or 100 km/h, for example, it is not twice but four times longer than at 30 mph or 50 km/h. Tire traction is also less effective when the roads are wet and slippery. Therefore, always maintain a safe distance.

Moisture or road salt on brakes can affect braking distance

Driving through water may reduce tire traction. Moisture on brakes from road water, car wash or coating of road salt may affect braking efficiency. Cautiously apply brakes for a test. Brakes will dry and salt coating will be cleaned off after a few cautious brake applications.

Brake wear

Audi automobiles have excellent brakes, but they are still subject to wear, depending on how the brakes are used. Have the brake system inspected at the intervals recommended in your Maintenance Schedule.

The driving positions

The Automatic Transmission has 3 forward driving positions and one reverse. In the positions D and 2, the Automatic Transmission changes gears automatically while driving.

Position D is for normal city and highway driving. It ranges from zero to top speed, and all three gears shift automatically, depending on the speed and accelerator pedal position.

Position 2 and 1 are to be used for mountain driving or slow driving, and also when you want to make use of the engine's braking effect.

Position 2 should only be used up to 75 mph or 125 km/h. In "2", only the first and second gears will engage automatically. Therefore, only shift down into position "2" when the speed is below 75 mph or 125 km/h. It is not necessary to let up on the accelerator.

Position 1 is needed on rare occasions. It should only be used up to 50 mph or 75 km/h. In "1" the transmission will stay in first gear and not shift into the second or third gear. **Only shift down into "1" when the speed is below 50 mph or 75 km/h.**

Reverse

position should be selected only when the car has come to a full stop and the engine is running at idle speed.

Starting the engine

The selector lever must be in **NEUTRAL** or **PARK**. As long as one of the driving positions is engaged a safety switch prevents the engine from being started.

Emergency starting – Caution

Your Audi with Automatic Transmission **CANNOT BE STARTED BY PUSHING OR TOWING**. If engine does not start because of discharged battery, the car can be started with jumper cables.

Refer to "Emergency starting with jumper cables". Should the engine fail to start consult your nearest Audi dealer.

Selecting a driving position while driving (D–2–1)

While driving within the recommended maximum speed ranges, simply release the accelerator pedal and move the selector lever from the position you are in into the position you want. Then step on the accelerator again.

Moving off

With the parking brake or foot brake set, shift into the position you wish to use, usually position D. To move off, release the brake and accelerate.

Do not release the brake before you are prepared to move, because power is transmitted to the wheels as soon as a driving position is engaged.

Stopping

When stopping temporarily, at traffic lights for example, it is not necessary to move the selector lever to Neutral. Simply apply the brakes. To start again release brake and accelerate.

Parking

When parking your car, apply the parking brake first, and then move the selector lever completely to position P. To do this, depress the button and push the lever through R to P. The transmission is then mechanically locked. **SHIFT OUT** of the Park position, before releasing the parking brake.

When the car is parked on a steep hill, shifting out of Park may be a little harder. This is due to the weight the car exerts on the transmission.

Do not remove the key from the ignition/steering lock until you have parked the car, because removal of the key locks the steering wheel.

**Genuine Audi Parts:
The people who built
your Audi
used them.
And so should you.**

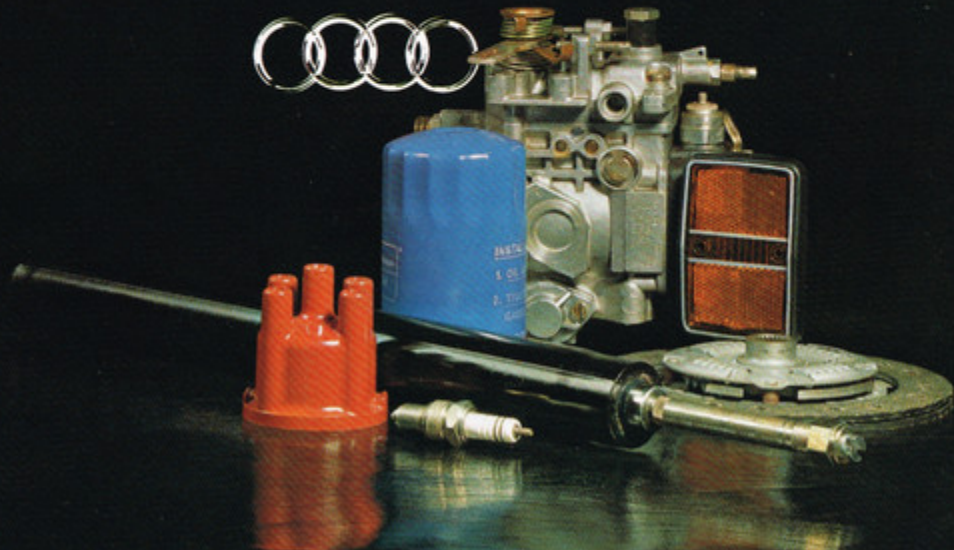

There are only Genuine Audi Parts in your new Audi. That's one reason why it runs like a new Audi.

No one knows your new Audi in quite the same way as the people who built it. And when it comes to replacement parts, we build them to the same standards and specifications as the original equipment. We've made sure that these genuine replacement parts are built with the same enduring quality that you would look for in a new Audi.

To be sure you're getting the best in genuine replacement parts for your Audi, ask your dealer about the Autobahn line of parts. It's a convenient way of choosing from among the most popular maintenance and replacement parts with the kind of quality that you want to put in your automobile.

Shown on the opposite page are just a few of the genuine replacement parts available at our parts department. We'll be glad to help you select the right ones for your car.

And they are backed by our Limited Parts Warranty. Even after your New Car Warranty has run out and you have a repair performed, our Limited Parts Warranty ensures that we will repair or replace every defective Genuine Audi Part, used in the repair, for 6 months or 6,000 miles, whichever comes first.*



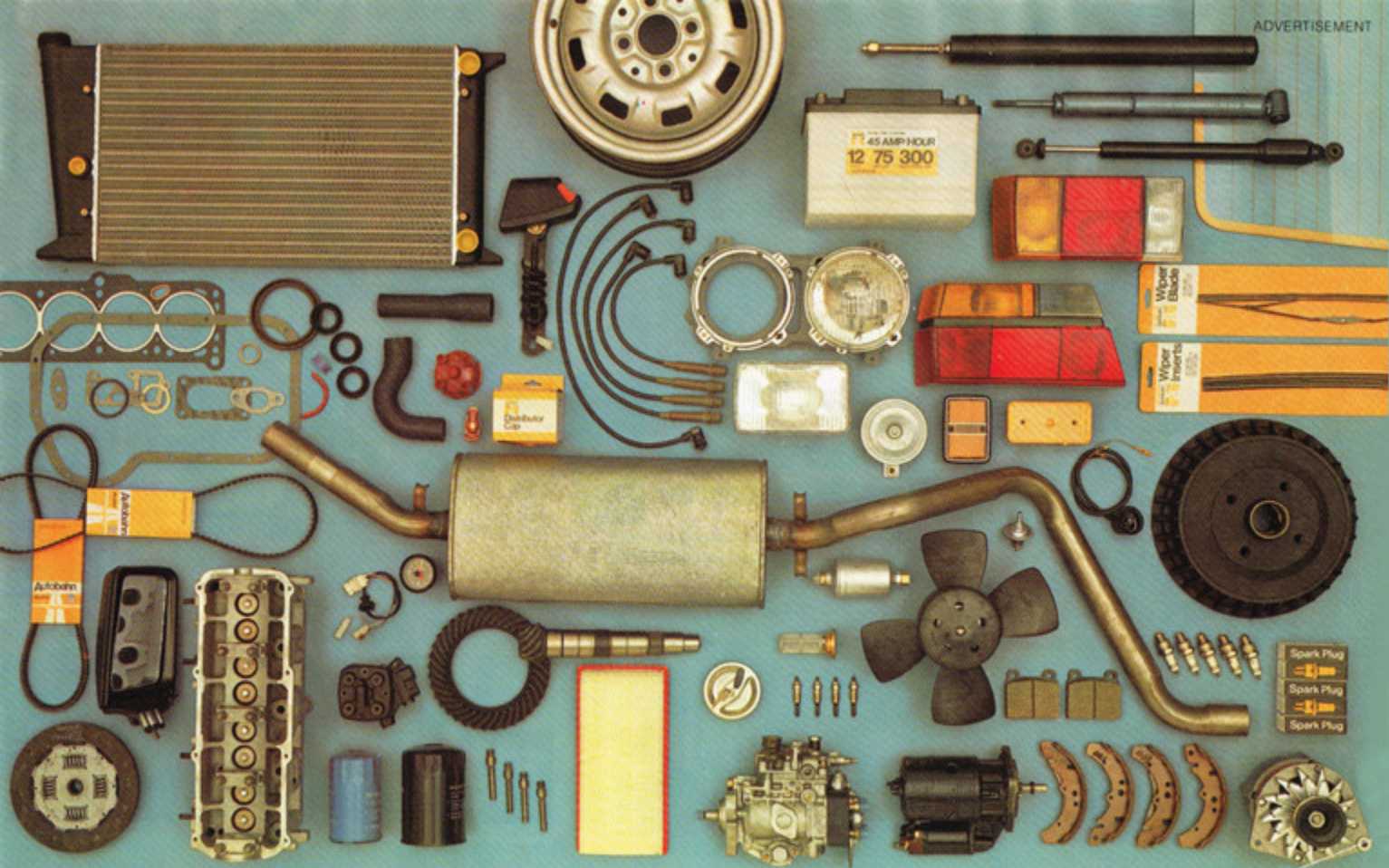

Autobahn® Accessories. A continuing story.

Why not shop for your accessories in the same place you would for high quality replacement parts.

Your dealer parts department will have them. A wide range of options from wheel covers and roof luggage carriers to floor mats and radios.

Speaking of sound, your dealer can bring you up-to-date with some of the best car audio equipment you could find anywhere. Including our remote CB, featuring microphones with integrated controls.

And don't forget about our car care products. They're especially formulated to help maintain your car's top running condition and good appearance for many years to come.

See our parts department for assistance in selecting from our complete line of Autobahn accessories—they're custom designed for your car.

Autobahn®



Neutral

Shift to this position for standing with brakes applied.

Never use Neutral for coasting downhill. You may lose control over the vehicle because of reduced braking and cause serious damage to the transmission when a driving position has to be selected.

Maneuvering

When alternating between forward and reverse drive – for instance, while maneuvering the car into a tight parking space – only shift into Reverse or Drive when

- ... the car has come to a full stop,
- ... and the engine is running at idle speed.

Stuck in snow, mud or sand

When alternating between Drive and Reverse in an effort to free the vehicle, depress the accelerator pedal lightly while the transmission is in gear, and release the accelerator pedal while shifting. Do not race the engine and avoid spinning the wheels.

Do not repeat “rocking” back and forth with wheels spinning at high engine speed and heavy throttle, as serious damage may be caused to the automatic transmission and other critical parts.

If you cannot free the vehicle after a few “rocking” attempts, call for help or a tow truck.

Accelerator “Kickdown”

When depressing the accelerator pedal you will find resistance at the full throttle position. By applying greater pressure the pedal can be pushed beyond this point to the kickdown position. The transmission will now shift automatically into the next lower gear to give you maximum acceleration, and only shift up again after the engine has reached maximum speed in that particular gear.

Observe the following when applying the accelerator kickdown:

- With the selector lever in D, you can apply the kickdown to make the transmission shift down into second gear when driving below 70 mph or 120 km/h and down to first gear when driving below 40 mph or 60 km/h.
- With the selector lever in “2”, you can apply the kickdown to make the transmission shift down into first gear when driving below 40 mph or 60 km/h.
- As soon as you release the pedal from the kickdown position the next higher gear is automatically engaged.

Be careful when using the kickdown on slippery roads. Rapid acceleration may cause skidding.

CLIMATE CONTROLS

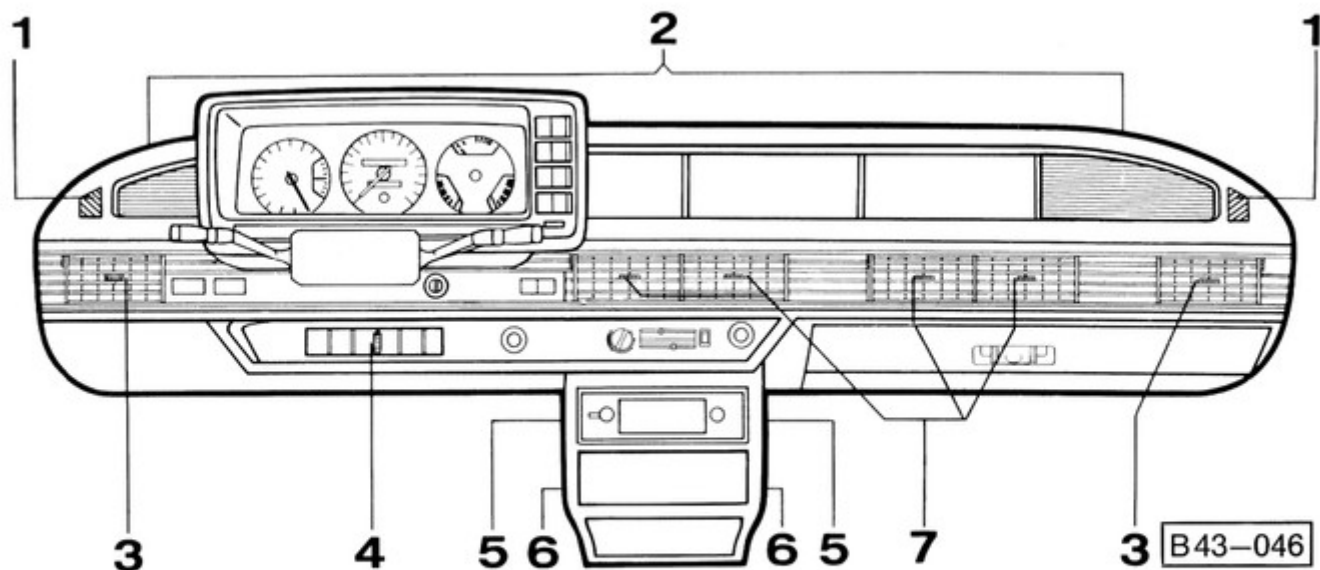

Ventilation/heating and factory installed air conditioner (Optional equipment)

All vents are for warm and outside air.

- | | |
|--|--|
| 1 - Side window nozzles, left and right (for defogging and defrosting) | 4 - Vents for driver (can also be closed) |
| 2 - Vent over full width of windshield | 5 - Vents for front footwells |
| 3 - Vents, left and right (adjustable to direct air flow for defogging/defrosting side windows. Vents can also be closed) | 6 - Vents for rear footwells |
| | 7 - Vents for front passenger (adjustable to direct air flow. Vents can also be closed) |

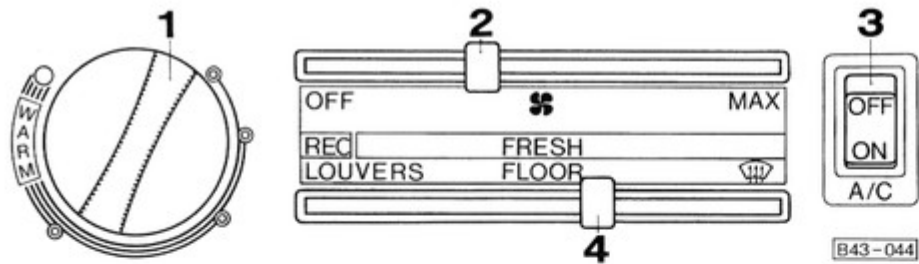

Air distribution

Outside air is drawn into the car interior through the air inlets in front of the windshield. Used air is withdrawn through openings below the rear window.

Air is distributed in the car interior through outlets 1-7. Outlet 2 directs air flow towards the windshield. Air flow from outlets 3 and 7 can be adjusted for direction or outlets can be shut off completely.

Outlets 4, 5 and 6 can only be opened or shut off.

Always be sure that air intakes and outlets are unobstructed.

Temperature control knob (1)

By turning the rotary knob clockwise or counter-clockwise, you can control the temperature inside your Audi, regardless of outside temperatures. Maximum heating output and fast defrosting can be obtained only after the engine has reached operating temperature.

Heating

- Turn knob clockwise to WARM (red dot)
- Maximum heating is achieved with knob at WARM
- Use any intermediate position for less heat.

Ventilation/cooling

- Turn knob counter-clockwise to blue dot.

Fan speed control lever (2)

Use this lever to control the air volume.

OFF = No air flow

☼ = Medium air flow

MAX = Fan operates at "high" speed.

By moving the lever from "OFF" to "MAX" the control can be set at each speed between.

Air conditioning switch (3)

(where applicable)

Flip switch to A/C to turn the air conditioning system on. When outside temperatures drop to +41° F or + 5° C, the system shuts off automatically. When temperatures rise, the system automatically switches on again.

If outside air ventilation is sufficient for comfort, or saving fuel is important, turn the air conditioner off.

Air distribution control lever (4)

Use this lever to direct air flow through air outlets for the side windows, the windshield, the footwells, and the dashboard vents.

REC – Air conditioned air inside the car is recycled for maximum cooling.

LOUVERS – All air flows through dashboard vents. Footwell nozzles and side window/windshield defogger nozzles are closed.

FRESH – Outside air entering the car's interior is used for air conditioning and cooling is less intensive.

FLOOR – Footwell nozzles open. Air flows through side window/windshield nozzles and dashboard vents.

 – Side window/windshield defogger nozzles open. Footwell nozzles and dashboard vents are closed.

Operating hints

To direct all warm air flow toward the windshield and side windows.

- Turn temperature control knob (1) to WARM (red dot).
- Move fan speed lever to MAX.
- Move air distribution lever (4) to 

Outside air ventilation

- Turn temperature control knob (1) clockwise to blue dot.
- Move fan speed lever (2) to desired fan speed position.
- Move air distribution lever (4) to desired air outlet position.

Mixing cool and warm air

- Turn temperature control knob (1) to desired heating output.
- Move lever (2) to desired fan speed.
- Move lever (4) toward FRESH.

These adjustments will provide a pleasant mixture of cool/warm air circulation. The air in the car will be dehumidified and fogged up windows will clear up.

Air conditioning

When the air conditioner is on, temperature as well as humidity inside the vehicle is controlled. During high outside humidity, you can prevent windshield and windows from fogging by setting the controls accordingly.

Maximum cooling is maintained with windows closed. However, when the vehicle interior is very hot from standing in the sun, open a window for a few minutes to permit hot air to escape.

For maximum cooling,

- Turn temperature control knob (1) clockwise to blue dot.
- Move fan speed lever (2) to MAX.
- Move air distribution lever (4) to REC.

In this position, the cooled air inside the car is recycled through the system and cooling is further increased.

Since no outside air circulation takes place we recommend to use the REC position primarily for fast cool-down or for short and intermittent intervals only. Use the FRESH lever position for normal operation.

With lever (4) in position FRESH, outside air entering the car's interior is used, and cooling is less intensive.

Notes

- Keep windows closed when air conditioner is operating.
- Keep air outlets unobstructed by clothing or any other articles to prevent windows from fogging.
- It is not necessary to turn the air conditioner off when restarting a stalled engine. The current to the air conditioner is interrupted during the starting process.

Should you suspect that your air conditioner is damaged have it checked promptly for leaks or other damage. Leaks must be sealed immediately since loss of refrigerant may result in serious damage to the air conditioning system.

If cool air flow stops completely...

Turn the air conditioner off. See your dealer to have the condition corrected. Your dealer has the qualified personnel and proper workshop equipment.

If cool air flow decreases...

The evaporator may be icing up. To permit the evaporator to defrost, turn the air conditioner off and increase the fan speed. After the evaporator has defrosted, the controls can be reset for maximum cooling.

If the engine tends to overheat...

Turn the air conditioner off until the coolant temperature reaches a normal level.

Maintenance

The condenser should be checked periodically for cleanliness. If clogged with dirt or insects, the condenser should be washed down with water.

After the winter months and before extended summer usage, the air conditioner should be checked and, if necessary, serviced by your dealer.

Payload reduction

The weight of the air conditioner installed in your car reduces the vehicle's capacity weight. For weight information, see sticker on left door jamb.

DO-IT-YOURSELF SERVICE

Cleaning your Audi

The paint on your Audi is very durable, and so is the upholstery. But a car can get a lot of abuse from industrial fumes and corrosive road salt to abandoned lollipops and muddy dog feet.

A well-cared-for Audi can look like new 10 years later. It all depends on the care the owner is willing to give to the car.

Your Audi dealer has a number of car-care products and can advise you which ones to use for cleaning the interior and exterior of your car.

- **Always read directions on the container before using any product.**
- **Most chemical cleaners are concentrates which require dilution.**
- **Observe caution labels.**

Following are a few hints on how to keep your Audi looking young and beautiful.

Washing your Audi

The longer the dirt is left on the paint, the greater the risk of damaging the glossy finish, either by scratching if the dirt is rubbed into the paint, or simply by the chemical effect dirt particles have on the paint surface.

- **Do not wash your car in direct sunlight.**
- **Do not wash or dry your car with the engine running.**
- **Do not clean the underside of chassis, fenders, wheel covers, etc. without protecting your hands and arms. You may cut yourself on sharp-edged metal parts.**

Wash your car often, use plenty of water, a car-wash and wax solution and a soft sponge or hose brush. Begin by spraying water over the dry car to remove all loose dirt before applying the car-wash and wax solution.

Use plenty of water to rinse the car off. Wipe the car dry with a chamois to avoid water spots.

Waxing

Waxing is not really needed when you have washed your car with a car-wash and wax solution. If you do not use a car wash liquid with wax, apply wax to preserve the natural shine of the car.

To obtain a long lasting wax finish apply hard wax eight to ten weeks after buying the car. Wax again when water remains on the surface in large patches instead of forming beads and rolling off.

Polishing

Use a polish later in the car's life when the paint appears dull and loses its shine. Do not polish the new car. Always apply wax after polishing if the polish you are using does not contain a wax.

Any combination wax polish polishes your car, removes paint oxidation and also waxes your car.

Outside mirrors

When cleaning the outside mirror surface, use a mild soapwater solution only. Strong chemical or abrasive cleaning agents will damage or remove the mirror's non-glare coating.

Cleaning windows

Clean all windows and the windshield regularly to remove road film and car-wash wax buildup.

Use an alcohol base cleaning solution and a sponge or soft cloth. Dry with a chamois.

Weatherstrips

To seal properly, weatherstrips around windows and doors must be pliable. To retain flexibility of the rubber, spray with silicone or coat with talcum powder.

Windshield wiper blades

Remove the wiper blades periodically and scrub with a hard bristle brush and alcohol or a strong detergent solution.

Metal trim

Bright or black anodized trim will come clean during the car wash process. To protect the trim, use car wax.

Care of plastics

Plastic parts, such as decorative stripes, panels, bumpers, etc., will come clean during normal car washing. Should additional cleaning or spot removal be necessary, use a soft brush or cloth soaked with a mild detergent solution. Then rinse thoroughly and immediately with clear water.

Do not use anything which could mar the finish of the plastic surface, such as wax or polish, harsh detergents or chemical cleaning solvents.

Touch-up paint

Your dealer has touch-up paint for minor scratches and stone chips. Scratches should be touched up soon after they occur. The paint code for your car is on the vehicle identification label (see page 8).

Care of chassis

The underside of the car picks up dirt and salt and should be sprayed with a powerful jet of water. This is easier to do after the car has been driven in rain.

Removing spots – WARNING

Do not use gasoline, kerosene, naphtha, nail polish remover or other volatile cleaning fluids. They may be toxic or flammable or hazardous in other ways. Only use spot removing fluids in well ventilated areas. Keep them out of reach of children.

Tar

Do not allow tar to remain on the paint finish. Remove it as soon as possible with a cloth soaked with a special paint cleaner. If you do not have a tar remover, you may substitute with turpentine. After applying a cleaning fluid, always wash with a lukewarm soap/water solution and apply a new wax coat.

Insects

Remove as soon as possible with a lukewarm soap/water solution or apply insect remover.

Tree sap

Remove with a lukewarm soap/water solution. Do not allow tree sap to harden on the paint surface.

Cloth upholstery and carpeting

Clean with a vacuum cleaner or a hard bristle brush. Dirt spots can usually be removed with a lukewarm soap/water solution.

Use spot remover for grease and oil spots. Do not pour the liquid on the cloth material. Dampen a clean cloth and rub carefully, starting at the edge and working inwards.

Leatherette and interior trim

Use all purpose cleaner or a dry foam cleaner.

Grease or paint spots can be removed by wiping with a cloth soaked with all purpose cleaner. Leatherette parts of the headliner and side trim panels can be cleaned with a soft cloth or brush and all purpose cleaner.



Fuses and relays

A failure in the electrical system may be caused by a blown fuse or a malfunctioning relay.

The fuse/relay box is located under the engine hood. The fuses are protected by a cover.

There are 6 round slots in the fuse box which can be used to carry spare fuses.

Replacing a fuse

Before replacing a fuse, turn off all lights and accessories and remove the ignition key to avoid damaging the electrical system.

When replacing a fuse, do not hold fuse by its metal parts. In case of repeated short circuits the new fuse will burn out again, causing possible injury.

- Lift the fuse box cover up.
- Turn all fuses between contact springs until metal fuse strips face upward. In a blown fuse the metal strip is separated.
- Take blown fuse out by carefully depressing the upper contact spring.
- Carefully install replacement fuses with metal strip facing up. The fuse must fit tightly between the contact springs – do not bend the springs.
- Close the fuse box cover.

If a fuse blows repeatedly, do not keep on replacing it. The cause of the short circuit or overload must be found. On no account should fuses be patched up with tin foil or wire as this may cause serious damage elsewhere in the electrical circuit. It is advisable to always carry a few spare fuses in the car.

Fuse arrangement

| No. | Amp | Electrical equipment |
|-----|-----|--|
| 1 | 25 | Air conditioner, large heater blower, tachometer |
| 2 | 8 | Not used |
| 3 | 8 | High beam headlight, left |
| 4 | 8 | High beam headlight, right |
| 5 | 16 | Fuel pump (CIS fuel injection) |
| 6 | 8 | Right side light, right tail light |
| 7 | 8 | Left side light, left tail light, engine hood illumination |
| 8 | 8 | Glove compartment light, license plate light, instrument panel illumination |
| 9 | 16 | Combination instrument, sliding roof, cruise control, horn |
| 10 | 25 | Radiator fan motor |
| 11 | 16 | Brake lights, left and right |
| 12 | 16 | Cigarette lighter, radio, clock, interior light, power operated antenna, electrical mirror |
| 13 | 8 | Low beam headlight, right |
| 14 | 8 | Low beam headlight, left |
| 15 | 16 | Back-up lights, wiper motor |
| 16 | 25 | Rear window defogger |
| 17 | 8 | Flasher unit, turn signals |

Additional fuses in fuse box

| | | |
|----|----|---------------------------|
| 18 | 25 | Power windows |
| 19 | 16 | Cigarette lighters – rear |
| 20 | 8 | Central locking system |

8 amp. fuses – white color
 16 amp. fuses – red color
 25 amp. fuses – blue color

Plug-in relays

To preclude any possibility of damage, we recommend you have a malfunctioning relay checked and exchanged by your Audi dealer.

Bulb chart

Always verify part numbers with your Audi dealer.

| Bulb for | Trade No. | U.S. Part No. | Canada Part No. |
|-----------------------------------|-----------|---------------|-----------------|
| Sealed beam headlights | | | |
| low and high beam | 4651 | N 019051.2 | N 019051.2 |
| high beam | 4652 | N 019061.2 | N 019061.2 |
| Front turn signals/parking lights | 1034 | ZVP 118034 | N 17738.2 |
| Side marker lights | | | |
| front | – | ZAP 118158 | N 17752.2 |
| rear | 1816 | ZAP 118816 | N 17717.2 |
| Rear turn signals | 1073 | – | N 17732.2 |
| Stop lights | 1073 | – | N 17732.2 |
| Tail lights | 67 | ZVP 118067 | N 17718.2 |
| Back-up lights | 1073 | – | N 17732.2 |
| License plate lights | 1816 | ZAP 118816 | N 17717.2 |
| Instrument illumination | 158 | ZAP 118158 | N 17752.2 |
| Interior light | 211 | ZVP 118211 | N 17723.2 |

All dashboard lights, such as illumination of instruments, operating controls, indicator and warning lights, should be repaired if necessary by your Audi dealer.

Your Audi dealer will be your most reliable source of supply. Replacement part numbers change from time to time, and your authorized Audi dealer will always have the most up-to-date information.

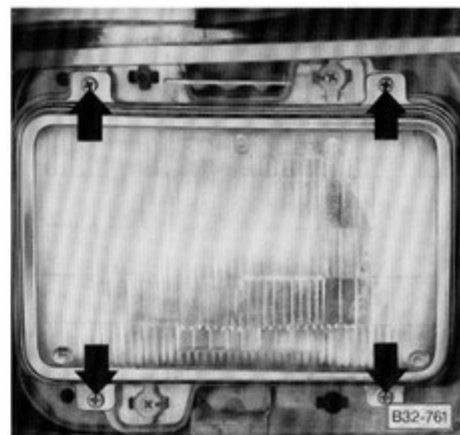
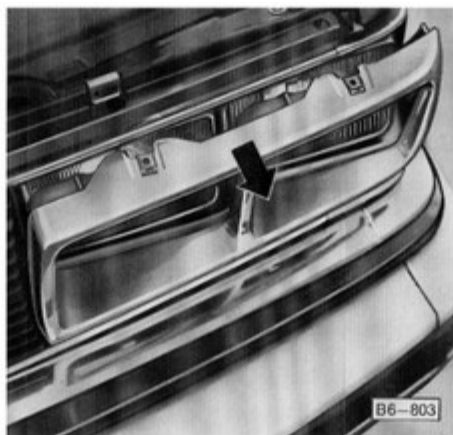
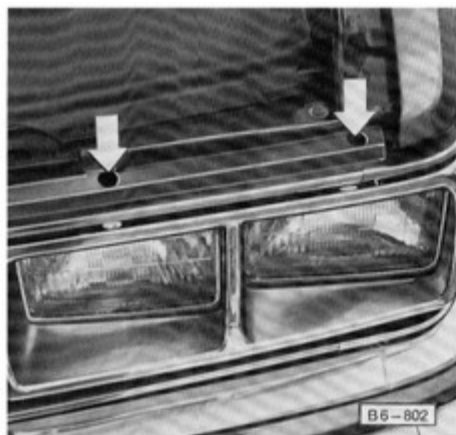

Replacing bulbs

Headlights

The inner sealed beam units are for high beam only and have one filament. The outer units are for low and high beams and have two filaments. Should it become necessary to replace a unit, first remove the grille.

- To do this, remove the two screws (arrows).

- Remove grille by swinging it in direction of arrow.

Note

Be sure to replace a Halogen sealed beam unit with a Halogen unit, and an incandescent sealed beam unit with an incandescent unit.

- Remove the four screws (arrows) and take off headlight retainer.
- Take sealed beam unit out of supports and disconnect cable connector.
- When installing the new sealed beam unit, the glass lugs must engage securely in their supports.

If no other headlight part as described here was removed or its position changed, it should not be necessary to aim the headlights. If in doubt have the adjustment checked by your dealer.

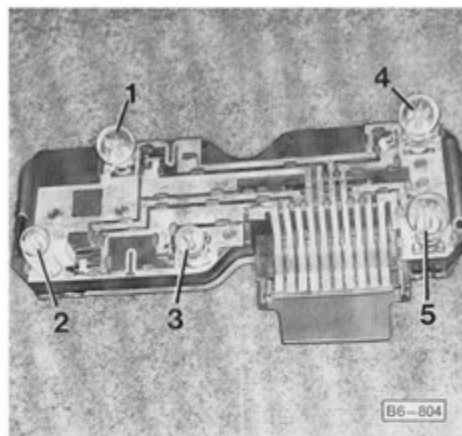

Rear turn signal, stop/tail light and back-up light bulbs (left side, illustrated)

- 1 – turn signal light
- 2 & 3 – tail lights
- 4 – back-up light
- 5 – stop light

The bulbs are accessible from the luggage compartment.

- Depress both clips of the bulb holder and pull out bulb holder.
- Gently press bulb into holder, turn, and remove bulb. Install new bulb.
- When reinstalling bulb holder in bulb housing, make sure both clips are properly engaged.

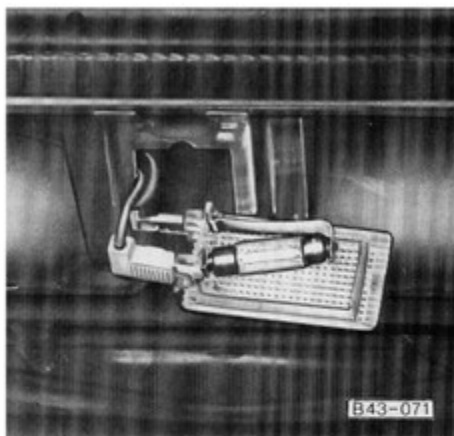

Luggage compartment light

- Insert a screwdriver between edge of the light housing and metal panel and carefully pry out the light housing.
- Remove faulty bulb and fit new bulb (festoon type).
- To reinstall the light housing, insert the side with the connector first, then press in the opposite side until firmly seated.

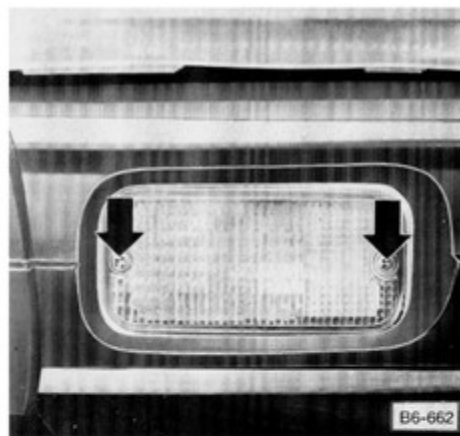

Front turn signal/parking light bulbs

- Remove both Phillips screws and take off lens.
 - Gently press bulb into holder, turn, and remove bulb. Install new bulb.
- Because of the asymmetrical pin arrangement of the double-filament bulb, there is no wrong way of inserting this bulb into the holder.
- Be sure the gasket is properly positioned when reinstalling the lens.
 - Tighten screws evenly. Do not overtighten as this may crack the lens.

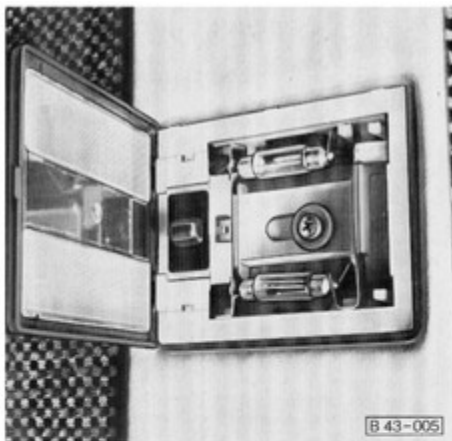

Interior dome light bulb

The lamp housing is held into place by spring clips.

- Carefully insert screw driver between side edge of housing and headliner and pry out.
- Remove bulb from between the two spring contacts and install new bulb.
- Reinstall lamp housing by inserting switch side first; then press in the other side until spring clip engages.

Interior light bulb on vehicles with electric sun roof (see illustration lower left).

- To replace a bulb, follow procedure outlined for dome light bulb.

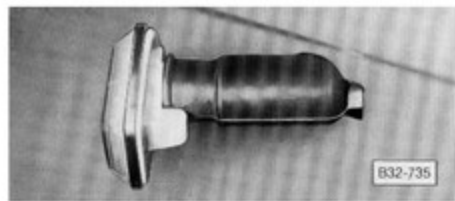

Side marker light bulbs (front)

- Carefully pry light cover away from fender with screw driver and pull out.
- Push rubber boot down and remove bulb from holder.
- Replace bulb and pull rubber boot back over holder.
- Press light cover back into fender opening until firmly seated.



License plate light bulbs

- Unscrew Phillips screws until lens can be taken off.
- Press bulb gently into holder, turn, and remove bulb.
- Install new bulb.
- Do not overtighten screws as this may crack the lens.

The license plate is properly illuminated only if both bulbs are operative.



The compact spare wheel

is stored in a recess underneath the luggage compartment floor and is held in place by a bracket and wing nut.

The compact spare wheel is designed to save space in your trunk, and its lighter weight makes it easier to install if a flat tire occurs. The lighter weight also helps to improve fuel economy and makes it easier to install if a flat tire occurs.

The compact spare wheel is for temporary use only and is so marked on the sidewalls.

Any continuous road use of the compact spare wheel may result in tire failure, loss of vehicle control and possible injury of vehicle occupants.

If a flat tire occurs, follow the jacking instructions on the following page, while keeping these points in mind:

- Check inflation pressure as soon as practical after installing the spare and adjust to 60 psi (4.22 kg/cm²) or 4.2 bar. This pressure should also be maintained while the wheel is stored.
- Do not drive at speeds in excess of 50 mph (80 km/h).
- The load carrying capacity is marked on the tire sidewalls and must not be exceeded.

Because this tire is smaller than the standard tire, vehicle ground clearance is reduced about 1-¼ inches/30 millimeters. Avoid driving over obstacles, and do not take your car through an automatic car wash when the spare is installed to avoid damage.

- The spare should be returned to the storage area as soon as the standard tire can be repaired or replaced.

- Because the compact spare was specifically designed for your car, it should not be used on any other vehicle.

- The compact spare wheel should not be mounted on any other wheels, nor should standard tires, snow tires, wheel covers or trim rings be used with the compact spare wheel. If such use is attempted, damage to these items or other vehicle components may occur.

WARNING

Do not put a snow chain on your compact spare. Because of the smaller tire size the chain will not fit properly. This can result in damage to your car, you could lose the chain and control of the vehicle.

Jack and Tools

are attached to the right side of the luggage compartment.

The car jack must never be used as a support to work underneath the car. If the jack is accidentally dislodged, you could be seriously injured. When working under the car, always use safety stands specifically designed for this purpose.

Wheels

(steel or light alloy)

Make sure the correct bolts are used at all times. If the bolt sizes are interchanged, wheel attachment will not be secure.

When changing wheel types, consult your Audi dealer.

See also sticker in luggage compartment.

The tightening torque is:
80 ft lbs (110 Nm).

Changing a wheel

- If you have a flat tire, move a safe distance off the road. Turn on the emergency flasher. In addition, mark the position of your car with flares or other warning devices to alert other motorists.
- Before you change a wheel, be sure the ground is level and firm. If necessary, use a board.
- Set the parking brake and block the wheels opposite the flat tire on the other side of the car.
- Never jack the car up by the body or the bumpers.
- The jack should only be used for changing a wheel. Do not use it as a support to work underneath the car.



To loosen – turn counterclockwise
To tighten – turn clockwise

Step 1

Take tools with jack and spare wheel out from luggage compartment.

Step 2

Remove protective caps off hub and wheel bolts with screwdriver.

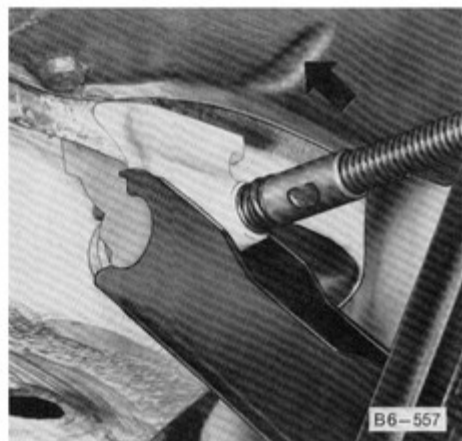

Step 3

Loosen all wheel bolts counterclockwise about one turn with the lug wrench. Insert the breaker bar to make full use of its leverage. **Do not yet remove the bolts.**

Step 4

There are two jack supports on each side under the body marked with an embossed triangle.

Jacking at any other place may damage the car or may result in injuries.

Provide a **firm base for the jack on the ground**. If necessary, use a board.

- Securely place jack under the jack support closest to the wheel to be changed.
- Guide the lifting hook of the jack under the car body. The firm ridge underneath the car should insert in the notch on the lifting hook.
- Place the jack at an angle so that the jack base is slightly under the car, and the longer portion of the jack base rests firmly on the ground.

Step 5

Never jack the car up by the body or the bumpers.

Do not raise the car until you are sure the jack is securely engaged.

Passengers should not remain in the car when the car is jacked up.

- **To raise the car, turn the handle clockwise. Only raise the car as much as is needed to change a wheel.**

Step 6

- Fully unscrew the wheel bolts. Place the spare wheel against the wheel hub so that the bolt holes in the wheel are in line with the threaded holes in the wheel hub.

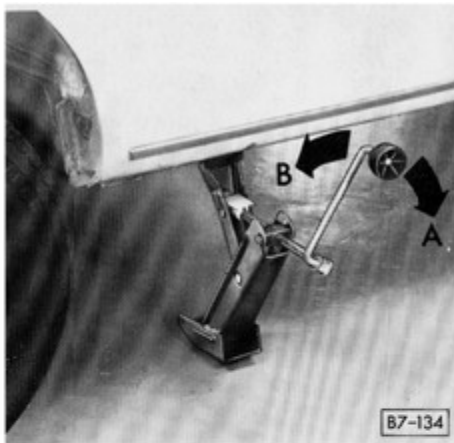

To raise – turn clockwise (A)
To lower – turn counterclockwise (B)

- Insert the wheel bolts and handtighten them crosswise before lowering the car.

Step 7

- **To lower the car, turn the handle counterclockwise until the tire touches the ground.**

Step 8

- Then go crosswise from one bolt to another tightening them firmly with the lug wrench and breaker bar.

Correct tightness of the wheel bolts is very important for operating safety.

- Correctly tightened bolts should have a torque of 80 ft lb or 11 mkg. This torque can be obtained with lug wrench and breaker bar by any person of average strength. If in doubt about the correct tightness of the wheel bolts have it checked with a torque wrench by your dealer or a service station.

Step 9

- Check inflation pressure of the installed compact spare tire. The cold tire inflation pressure should be 60 psi (4.22 kg/cm²) or 4.2 bar.
- Store jack, tools and wheel with damaged tire in the trunk.

Remember that the compact spare tire is constructed for temporary use only.

Refer to page 61 for details regarding limitations on use of the compact spare tire.

Step 10

- Have the standard road tire repaired promptly and remounted on the car as soon as possible.

Winter operation

Coolant

For year round driving, your car is delivered with anti-freeze coolant in the radiator for temperatures as low as -13°F/ -25°C for U.S. -40°F/ -40°C for Canada.

Coolant for summer driving

Because of its anti-corrosion properties, anti-freeze must also remain in the cooling system for summer operation.

Increasing the anti-freeze in the coolant further than shown in the table is not only uneconomical, it is also detrimental to engine cooling.

Anti-freeze concentration

At the beginning of the winter season, have the coolant checked for anti-freeze concentration, particularly if you had added only clear water before. Use any quality phosphate-free anti-freeze containing ethylene glycol. Such anti-freeze is available at your Audi dealer.

The ratio between water and anti-freeze depends on the anticipated outside temperatures. The ratios can be taken from the mixing table below or from the mixing ratios specified on the container of the anti-freeze manufacturer.

WARNING – HOT RADIATOR

Before checking anything in the engine compartment, let the engine cool down.

The fan switches on automatically when the coolant reaches a certain temperature and continues to run (even with engine stopped) until the coolant temperature drops. Therefore, never touch the fan blades as they will rotate spontaneously when the thermostat turns the fan on.

Be careful when removing the cap from the expansion tank when the engine is hot. Protect your hands, arms and face. Turn the cap very slowly and allow pressure to escape before removing the cap.

Engine oil

tends to thicken at low outside temperatures which may cause starting difficulties. Refer to the viscosity chart under "Lubricants" to be sure the viscosity of the engine oil in your car corresponds with the outside temperature recommendation.

When using multigrade oils there is generally less need for a seasonal oil change. Engine oil is necessary to lubricate all moving parts in the engine and also for engine cooling.

If you drive mostly short distances in city traffic in the winter, have your engine oil changed more frequently.

Mixing table

| For outside temperatures down to | | anti-freeze | | water | |
|-------------------------------------|-----|-------------|--------|--------|--------|
| °F | °C | U.S.qt | liters | U.S.qt | liters |
| -13 | -25 | 4.0 | 3.8 | 6.0 | 5.6 |
| -22 | -30 | 4.5 | 4.2 | 5.5 | 5.2 |
| -31 | -35 | 5.0 | 4.7 | 5.0 | 4.7 |
| -40 | -40 | 5.5 | 5.2 | 4.5 | 4.2 |

- Make it a habit to check the engine oil level with every fuel filling. Lack of oil may lead to serious engine damage.
- Always use the dip stick to check the oil level.

The oil pressure warning light is not an oil level indicator.

See "Engine oil checking and changing" for more details.

Transmission oil

For the Automatic and Manual Transmission there are no special winter instructions.

Spark plugs

Make sure the spark plugs are not worn or have a gap larger than 0.028 inch./0.7 mm. For further details see "Spark plugs".

Battery

During the winter months, the battery is subjected to greater use than in the summer. More power is consumed when starting at very low temperatures. Lights, wipers and rear window defogger are used more often. Battery capacity also tends to decrease as temperatures drop. Therefore, it is important to keep your battery in the best possible condition. If you mainly drive short distances or in the city traffic, have the battery checked and, if necessary, charged between regular maintenance services. See "Battery charging".

WARNING

Do not expose battery to open flames or electric sparks. Hydrogen gas generated by the battery is explosive. Do not let battery acid come in contact with skin, eyes, fabric or painted surfaces.

Winter tires

See page 67.

Snow chains

Use for front wheels only

Check with local authorities for possible restrictions. Only use chains with fine pitch links protruding no more than 1/2in/15 mm from tire tread and side walls, including tensioner. Wheels must rotate freely in all steering positions with chains mounted to prevent damage to body, front axle or brake components.

Remove chains when roads are free of snow.

Door locks

Door locks can freeze. When washing your car in the winter, do not aim the water jet directly at the locks. Put tape over the key-holes to prevent water from seeping in.

Water in the locks should be removed with compressed air. Squirt lock de-icer into the lock cylinders to prevent freezing. To free a frozen lock, warm up the key before in-

serting it, or warm the lock. Do not use hot water as it will freeze later.

Windshield wipers

Always loosen frozen wiper blades from windshield. They may tear otherwise.

Windshield washer

Always use a windshield washer solvent with anti-freeze to prevent the fluid from freezing. Follow instructions on the can.

Do not use engine coolant anti-freeze or any other solution that can damage the car paint.

Emergency equipment

It is good planning to carry emergency equipment in your car. Some of the things you should have are: window scraper, snow brush, container or bag of sand or salt, flares, small shovel, first-aid kit, etc.

Free the air intake grille in the front hood from snow and ice, so that the heater works properly.

Tires

The original equipment tires on your car comply with all applicable Federal Motor Vehicle Safety Standards. For "winter tires" see following page.

Tire pressures

For good car handling and long tire service life, it is important to maintain recommended tire pressures. Tires inflated above or below specifications can cause increased wear, high gas consumption and affect road holding of the car. Audi recommended cold tire inflation pressures are listed on a sticker on the fuel filler flap.

Always use tire pressure gauge when checking inflation pressures. Do not exceed the maximum tire inflation pressure listed on the tire sidewall. Cold tire inflation pressure means: when a car has not been driven for at least 3 hours or less than 1 mile.

Always include the spare tire when checking tire pressure.

Wheel balancing

A wheel should always be balanced after a tire repair. Even with regular use a wheel can get out of balance, and should therefore be balanced from time to time. Unbalanced wheels may affect car handling and tire life.

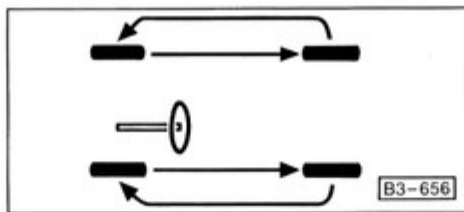

Tire Life and Rotation

Tire life depends on various factors, i. e., roads, traffic and weather conditions, driving habits, type of tires and tire care.

Inspect your tires at least every 2000 miles or 3000 km for wear and damage. If you notice uneven or substantial wear, wheels might need alignment or tires should be balanced or replaced when necessary.

Tire manufacturers recommend rotation every 7500 miles or 12,000 km for radial belted tires. Rotation and balancing, although an expense to you, will prolong tire life. The sketch illustrates how tires should be rotated.

Tires must always remain on same side of vehicle.

After rotation adjust tire pressure and torque wheel bolts diagonally to 80 ft lb/11 mkg (please refer to "Wheel changing" on pages 62-63).

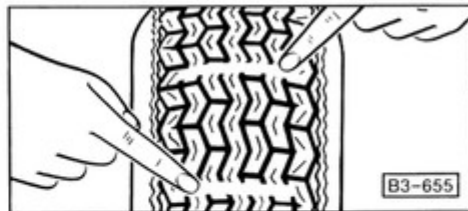

Tire wear

The original equipment tires on your Audi have built-in tread wear indicators. They are molded into the bottom of the tread grooves and will appear as approximately $\frac{1}{2}$ in (12 mm) bands when the tire tread depth is down to $\frac{1}{16}$ of an inch (1.6 mm).

When the indicators appear in two or more adjacent grooves, it is time to replace the tires. We recommend, however, that you do not let the tires wear down to this extent.

Worn tires cannot grip the road surface properly, and are even less effective on wet roads.

Do not drive with worn tires or tires showing cuts or bruises as they may lead to sudden deflation.

If you notice that tires are wearing unevenly, consult your Audi dealer. Uneven wear may not always be due to improper wheel alignment. It can be the result of individual driving habits such as cornering at high speeds. If the tire pressure is not checked and adjusted regularly, abnormal tire wear can also occur.

Tire replacement

In the interest of maximum safety and best allround car handling, always buy replacement tires that have the same specifications with regard to tire size, design, load carrying capacity, tread pattern, tread depth, etc. This also applies to Audi-recommended alternate replacement tires. If your tires are worn down near the safe limit, replace all 4 tires at the same time. If this is not possible, replace tires in pairs, either front or rear. Do not combine tires of different design, size or tread pattern. Tire specifications are imprinted on the sidewall of the tires. If in doubt, check with your Audi dealer.

Whenever replacing a tubeless tire, always install a new valve stem.

- New tires do not possess maximum traction. They tend to be slippery. Break new tires in by driving at moderate speed for the first 100 miles or 160 kilometers.
- Tire repairs should be left to a specialist only.
- Conventional bias ply tires should not be used.

Tire care

- Replace worn or damaged tires promptly.
- Avoid damaging tires and wheel rims. If you must drive over a curb or other obstacle, drive slowly and at an angle.
- Frequently check tires for uneven wear and damage.
- Remove imbedded material.
- Replace missing valve dust caps.
- Keep oil and gasoline from tires.
- Keep tires inflated correctly.

Winter tires

Winter tires are not absolutely essential on cars with radial ply tires, because radial ply tires are very good on winter roads.

For a better grip on snow and ice use **RADIAL PLY M + S TIRES** or winter tires with studs. Check with your local Motor Vehicle Bureau for possible restrictions.

Because of the special design characteristics of **RADIAL PLY M + S TIRES**, they should be inflated 3 psi above the cold tire inflation pressures recommended for the regular radial ply tires. However, do not exceed the maximum tire inflation pressure listed on the tire sidewall.

Winter tires should have the same load capacity as original equipment tires and should preferably be mounted on all four wheels.

Winter tires with studs should be run at moderate speeds when new in order to give the studs time to settle.

Tires with badly worn treads and studs are very dangerous. Make sure they are replaced promptly. Winter tires do not fulfill their purpose if the tread depth is less than $5/32$ in (4 mm).

For safety reasons, it is not advisable to drive a vehicle with winter tires at prolonged high speed. You cannot expect winter tires to have the same degree of traction on dry, wet or snow-free roads as a normal tire. Furthermore, winter tires wear rapidly under these conditions.

Removing and storing tires

The driving direction should be clearly marked on all tires before removing them for storage. This is to make sure that they are mounted and run in the same direction as before. When remounting, put the tires with the most tread depth at the front. Have the tires/wheels balanced as soon as possible.

Store tires in a cool and dry place.

Exercise extreme caution when working under the engine hood

The engine compartment of any motor vehicle is a potentially hazardous area. If you are not fully familiar with proper repair procedures, do not attempt the adjustments described on the following pages.

These WARNINGS apply to the entire vehicle.

- Before working on any part in the engine compartment, turn the engine off and let it cool down sufficiently. Hot engine compartment components can burn skin on contact.
- Even after the engine is stopped the fan may continue to run until the temperature of the coolant has dropped to a certain level. Therefore, never touch the fan blades as they will rotate spontaneously when the thermostat turns the fan on.
- Exercise extreme caution to prevent neckties, jewelry or long hair from getting caught in the fan blades, the drive belts or any other moving engine parts.
- Be alert and cautious around engine at all times while the engine is running.

- If work has to be done with the engine running, always set the parking brake and make sure the shift lever is in either Neutral or Park.
- Do not smoke or allow an open flame around gasoline or battery.
- Keep a fire extinguisher in close reach.
- Always support your car with safety stands if it is necessary to work underneath the car. The jack supplied with the car is not adequate for this purpose.
- When working under the car without safety stands but with the wheels on the ground, make sure the car is on level ground, that the wheels are blocked with wedges and that the engine cannot be started. REMOVE THE IGNITION KEY.

- Incomplete or improper servicing may cause problems in the operating of the car. If in doubt about any servicing, have it done by your Audi dealer or any other properly equipped and qualified workshop.
- Improper maintenance during the warranty period may affect warranty coverage.

Engine oil

Engine oil consumption

It is normal for the engine to consume oil. The rate of oil consumption depends on the quality and viscosity of the oil, the speed at which the engine is operated, the climate, road conditions as well as the amount of dilution and oxidation of the lubricant.

Because of these variables, no standard rate of oil consumption can be established, but drivers should expect an increased oil consumption at high speeds and when the engine is new.

The engine in your car depends on oil to lubricate and cool all of its moving parts. Therefore the engine oil should be checked regularly and kept at the required level. Make it a habit to have the engine oil level checked with every fuel filling.

Lack of sufficient engine oil may lead to severe engine damage.

The difference between the “min” and “max” marks on the dipstick is about 1 U.S. quart or 1 liter.

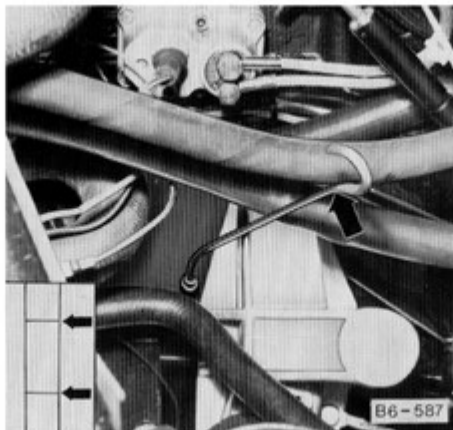

Checking the oil level

- To get a true reading, the car should be on level ground. After turning off the engine, wait a few minutes for the oil to return to the oil pan.
- Pull out dipstick (arrow) and wipe it clean with a rag.
- Reinsert dipstick: push it in all the way for an accurate reading.
- Pull dipstick out again. The oil level is correct if it is between the “max” and “min” marks on the dipstick.
- If oil level is below “min” mark, or not showing on dipstick, add oil immediately.

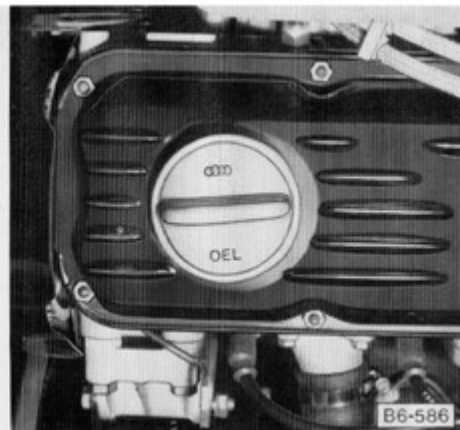

Adding engine oil

- Unscrew cap from cylinder head cover.
- Only add the amount of oil that is needed. Always select a quality oil. The correct oil grade and viscosity recommendation is given under “Lubricants”.
- Replace cap and handtighten securely.
- The oil filler cap must be secure to avoid oil spill causing fire hazard.

See WARNINGS on page 68.



Changing the engine oil

Change the oil in your engine regularly, but at least twice a year (see Maintenance Schedule). This is very important as the lubricating properties of oil diminish gradually during normal operation of the car.

If you drive mostly short distances or in dusty areas, the engine oil should be changed more frequently.

Drain the oil when the engine is still warm. Remove the oil drain plug (arrow) and allow the oil to drain. Always use a new gasket when re-installing the plug. Do not overtighten the plug.

When removing oil drain plug with your fingers, keep your arm as high as possible. This will prevent hot oil from running down your arm. Wear eye protection.

Fill the engine with oil labeled “For Service API/SE” See “Lubricants”.

Be mindful of how you dispose of used engine oil. Do not dump it on garden soil, wooded areas, into open streams or down sewage drains.

Local zoning ordinances or environmental regulations will tell you how you can dispose of it. Should the discarding of the old oil present a problem to you, we suggest you have the oil changed at your dealer or a service station.

Engine oil capacity is listed under “Capacities”.

Because of the detergent additives in the oil, the fresh oil will look dark after the engine has been running for a short time. This is normal and there is no reason to change the oil more often than recommended by the manufacturer.

See WARNINGS on page 68.



Changing the oil filter

The engine oil filter (A), as well as the turbo charger oil filter (B) should be changed at the intervals listed in your Maintenance Schedule.

- Loosen oil filter element with appropriate wrench and remove.
- Lightly coat new filter seal with oil.
- Screw on new filter element until seal just contacts the crankcase. Only hand-tighten according to filter manufacturer's instructions on the carton or on the filter element.
- Run the engine and check for leaks.

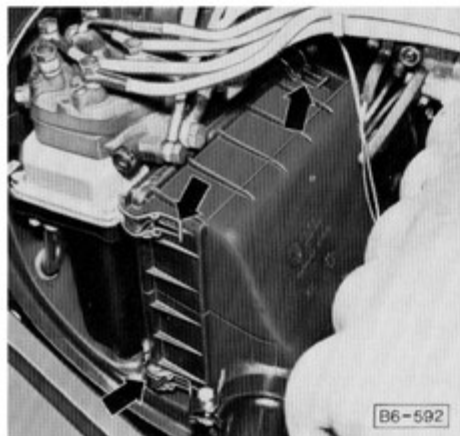

Air cleaner

All the dust present in the air drawn in by the engine is retained by the filter element in the air cleaner.

A dirty filter element not only reduces the engine output but can also cause premature engine wear.

Normally, it is not required to service the air cleaner more often than recommended in the Maintenance Schedule. If the vehicle is driven on very dusty roads, the air cleaner must be serviced more frequently, even daily.

Cleaning or replacing filter element

- Release four clips (arrows).
- Pull filter cover to right.
- Remove filter element.
- Lift out filter cover.
- Shake out filter element to remove dirt, or replace, if necessary.

WARNING

The paper filter element must never be cleaned or soaked with gasoline, cleaning solvents or oil.

Installing filter element

- Insert filter cover with intake pipe facing down.
- Reinstall filter element.
- Press filter cover against housing and close four clips.

WARNING

Turn the engine off. Do not touch the fan blades. They may rotate spontaneously. Let the engine cool down.

See WARNINGS on page 68.



Power assisted steering

The fluid level in the power assisted steering system must be checked at regular intervals. If fluid level drops below the "MAX" mark on the reservoir, add ATF Dexron®. Hand tighten the red filler cap securely.

If the engine is not running, power assisted steering is no longer effective. You can continue to steer the car; however, more effort will be required to turn the steering wheel.

Cooling System

Checking the coolant level

The cooling system capacity is listed under "Capacities" or "Winter operation" on page 64.

For year round driving, anti-freeze is added at the factory for temperatures down to $-13^{\circ}\text{F}/-25^{\circ}\text{C}$ for U.S.
 $-40^{\circ}\text{F}/-40^{\circ}\text{C}$ for Canada.

Because of its anti-corrosion properties, anti-freeze should also remain in the cooling system for summer operation.

WARNING

Before checking anything in the engine compartment, let the engine cool down. The fan blades will rotate spontaneously until coolant temperature drops.

Be careful when removing the cap from the hot expansion tank. Protect your hands, arms and face. Turn the cap very slowly and allow pressure to escape before removing the cap.

See WARNINGS on page 68.



Although a properly working cooling system requires little care, the coolant level should be checked from time to time, and always before going on a longer trip.

As the expansion tank is transparent, the coolant level can be checked without removing the filler cap.

- When the engine is **COLD**, the coolant level should be up to the tip of the arrow.
- When the engine is **WARM**, the coolant level should be somewhat above the tip of the arrow.

If you notice an unusual loss of fluid, there may be a leak in the cooling system. Have your dealer check and correct the condition.

Adding coolant

To maintain the anti-corrosion properties of the coolant, the anti-freeze concentration should not be reduced, even during the warm season. Always add anti-freeze and water in the ratio specified in the mixing table in chapter "Winter operation".

Cold anti-freeze and cold water should only be added to the expansion tank when the engine is cold too.

Use any quality phosphate-free anti-freeze containing ethylene glycol. Such anti-freeze is available at your Audi dealer.

Anti-freeze, other than specified by manufacturer, may cause corrosion of the cooling system, leading to engine overheating and damage.

Only for topping-up coolant, a small amount of anti-freeze containing ethylene glycol and phosphates may be used, if recommended anti-freeze is not available.

- After adding coolant, run the engine at idle speed for a few seconds.
- Wait for the radiator fan to switch on and off again.
- Check coolant level in the tank. Add more if necessary.



Cleaning or replacing spark plugs

Turn the engine off and let it cool down!

Removing spark plugs

Grasp the spark plug connector and pull it off. Do not pull on the ignition wires as they may separate from the connectors. Unscrew the spark plugs with a suitable spark plug wrench.

Cleaning spark plugs

Do not clean spark plugs with a sand blaster or by mechanical means. Clean small amounts of carbon deposits with a wooden or plastic pick. Use air drying when spark plugs are wet because of fuel or water.

The plugs should also be clean and dry on the outside to avoid shorting and arcing.

The gap can be set by bending the outside electrode. The gap should be 0.028 inch (0.7 mm).

See **WARNINGS** on page 68.

Installing spark plugs

Insert them by hand and screw them into the cylinder head as far as they will go. Only then use the spark plug wrench to tighten them firmly. Do not overtighten.

Spark plugs should be replaced according to the maintenance schedule, or when the deposits, oil fouling or wrong heat range cause misfiring.

Never remove a spark plug wire while the engine is running to check fouling or misfiring. Unburned fuel entering the catalytic converter can cause expensive damage.



V-belt tension checking

Correct V-belt tension is important as the V-belt drives the alternator, the water pump, the power assisted steering and the air conditioner compressor.

Before checking V-belt tension, turn the engine off and let it cool down.

The coolant fan switches on automatically when the coolant reaches a certain temperature and continues to run (even if the engine is turned off) until the coolant temperature drops.

Therefore, never touch the fan blades as they will rotate when the thermostat turns the fan on.

The tension is correct if the belt yields about 0.4 to 0.6 in/10 to 15 mm when pressed firmly with the thumb in the center between crankshaft and alternator pulley.

Tensioning and replacing of V-belts/drive belts should be performed by your Audi dealer or a qualified workshop.

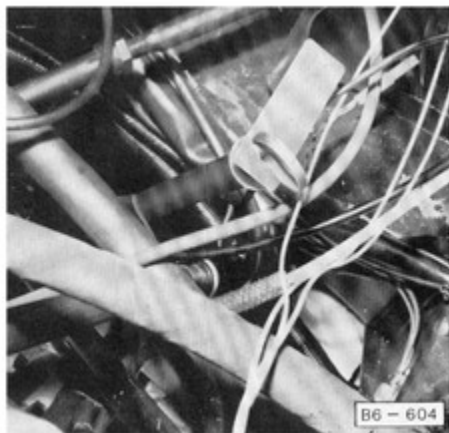

Automatic Transmission Fluid

The torque converter and the transmission are lubricated with Automatic Transmission Fluid (ATF).

Changing the ATF

The ATF has to be changed at specified intervals (see also Maintenance Schedule).

Do not tow the car or run the engine without ATF in the transmission.

The final drive requires hypoid oil SAE 90 only, which does not have to be changed.

Checking the ATF level

The ATF has to be checked at frequent intervals, for instance when the engine oil is being checked or at least at the specified intervals (see Maintenance Schedule). A correct ATF level is very important for the transmission operation.

The ATF should be checked with the engine warm; at idle and with the selector lever in Neutral and the parking brake applied.

The ATF-filler neck is in the engine compartment on the left side of the engine, as seen in driving direction. The dipstick is attached to the plug. Pull it out and wipe it clean. Reinsert the dipstick to measure the fluid level.

The automatic transmission may be damaged by even a tiny speck of dirt. Only use lint free rags to wipe the dipstick. Use a clean funnel or spout when adding ATF.

You have enough ATF if the fluid level is between the two marks on the dipstick. It should never be above or below these marks.

If level is too high or too low do not just add or drain ATF. Have your dealer check and correct the cause as soon as possible.

For correct ATF specifications, see "Lubricants".

See WARNINGS on page 68.



Brake fluid reservoir

The brake fluid reservoir is located at the rear partition of the engine compartment on the left side as seen in driving direction. The fluid level in the brake fluid reservoir should always be between the two marks "MAX" and "MIN". The brake fluid level is automatically monitored: if the brake fluid level falls considerably below the mark "MIN", the brake warning light will come on. The complete brake system should be thoroughly checked by your Audi dealer and the cause corrected.

Do not continue to operate the car.

Every 2 years the brake fluid has to be replaced.

See Maintenance Schedule.

If brake fluid must be added to the reservoir, use only new and unused DOT 3 or DOT 4 brake fluid that meets SAE specification J 1703 and conforms to Motor Vehicle Safety Standard 116. Using any other brake fluid, or using brake fluid that

has absorbed moisture from the open air, or brake fluid that is dirty, may cause premature wear or unreliable braking action.

Do not add or mix DOT 5 silicone type brake fluid with the brake fluid in your car as severe component corrosion may result. Such corrosion could lead to brake system failure.

WARNING

Brake fluid is poisonous. It is also harmful to the paint on your car.

See **WARNINGS** on page 68.

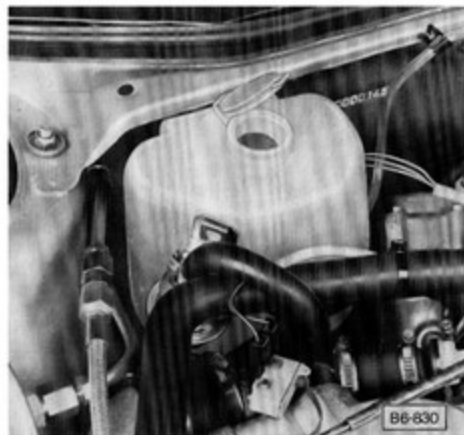

Container for windshield washer fluid

As clear water is usually not adequate for cleaning the windshield, add a cleaning solution to the water.

Follow the directions on the can for the correct amount to be used.

Use windshield washer solvent with anti-freeze all year round. It helps to keep your windshield clean and prevents freezing of fluid in the winter.

Do not use engine coolant anti-freeze or any other solution that can damage the car paint.

The windshield washer container is located at the rear partition of the engine compartment.

To add washer fluid just lift the filler cap by the small tongue. The container can be filled to the top. After filling the container press the cap onto the filler neck.

The capacity of the container is listed under "Capacities".



Battery (12 Volt)

The battery is located under the front hood at the rear partition of the engine compartment on the right side, as seen in driving direction.

In vehicles with FACTORY-INSTALLED AIR CONDITIONER, the battery is located under the rear seat, on left side as seen in driving direction.

See page 23 for "Emergency start assist".

See page 78 for "Emergency starting with jumper cables".

Electrolyte level

Under normal operating conditions, the battery in your Audi is maintenance-free.

At high outside temperatures it is advisable, however, to check the fluid level at regular intervals through the transparent battery housing. The fluid level should always be between the "min" and "max" marks in each cell.

If the fluid level is below the "min" mark, let your Audi dealer correct the condition.

WARNING

Do not let battery acid come in contact with skin, eyes, fabric, or painted surfaces.

If you get electrolyte in your eyes or on your skin, immediately rinse with cold water for several minutes and call a doctor.

Do not expose the battery to an open flame or electric spark. Hydrogen gas generated by the battery is explosive.

See WARNINGS on page 68.

Cleaning terminals and connections

The electrical system depends mainly on the battery. Therefore, the battery should be checked regularly and kept in good working condition.

The terminals and connections should be kept clean and coated with silicone spray or petroleum jelly. Make sure the ground connection to the body is tight and free of corrosion.

When working on the battery, be sure not to short circuit the terminals. This would cause the battery to heat up very quickly, which could lead to damage.

Never drive the car with a disconnected battery as this may damage the electrical system.

Before work is done on the electrical system, disconnect the negative ground strap at body and then the positive cable. To reconnect battery reverse the procedure.

Charging of Battery

WARNING

- Charge battery in a well ventilated area. Keep away from open flame or electrical spark. Do not smoke. Hydrogen gas generated by the battery is explosive.
- Electrolyte that may spill during charging should be washed off with a solution of warm water and baking soda to neutralize the acid.
- If you get electrolyte in your eyes or on your skin, immediately rinse with cold water for several minutes and call a doctor.
- Never charge a frozen battery. It may explode because of gas trapped in ice. Allow a frozen battery to thaw out first.
- Never use a fast charger as a booster to start the engine. This may seriously damage the car's electrical system and the charger.
- Fast charging a battery is dangerous and should only be attempted by a competent mechanic with the proper equipment.

See WARNINGS on page 68.

Slow battery charging

- It is not necessary to remove the battery from the car and it is also not necessary to disconnect the cables.
- Make sure the electrolyte level in each cell is between the "MIN" and "MAX" marks. If the fluid level is below the "MIN" mark, let your Audi dealer correct the condition.
- Normally, a battery should be charged at no more than 10 percent of its rated capacity. For example, a charging current of 4.5 Amp. would be used on a battery having 45 Ah. Rated capacity of the battery in your car is specified on the battery housing.

Heed all warnings and follow instructions that come with your battery charger.

Charging

Charger cables must be connected POSITIVE (+) to POSITIVE (+) and NEGATIVE (-) to NEGATIVE (-).

1. Charging rate not over 6 Amp.
2. Connect charger cables and switch on charger.
Do not connect or disconnect charger cables while charger is operating.
3. After charging, turn off charger and disconnect charger cables.

To remove battery from car

1. Disconnect negative ground strap.
2. Disconnect positive cable.
3. Unscrew bolt of holding plate with open end wrench.

To reinstall battery in car

4. Place battery in car and tighten bolt of holding plate.
5. Reconnect positive cable.
6. Reconnect negative ground strap.

Emergency starting with jumper cables

WARNINGS

- Improper use of a booster battery to start a car may cause an explosion.
- Lead-acid batteries generate explosive gases. Keep sparks, flame and lighted cigarettes away from batteries.
- Do not charge a frozen battery, thaw it out first. Gas trapped in the ice may cause an explosion.
- Check electrolyte level in each cell. If it is below the "min" mark, let your Audi dealer correct the condition.
- No attempt should be made to jump start any vehicle with a low electrolyte level in the battery.
- Make sure the voltage of both batteries is the same.
- The capacity (Ah) of the booster battery should not be lower than that of the discharged battery.
- Car with discharged battery: turn off lights and accessories, remove key, move lever to N or P and set parking brake.
- Car with booster battery should not be running. Disconnect ground cable.

How to use jumper cables

To avoid serious injury and damage to car, heed all warnings and instructions of the jumper cable manufacturer.

The jumper cables must be sufficiently long for vehicles not to touch.

Improper hook up of jumper cables can ruin the alternator. Always connect POSITIVE (+) to POSITIVE (+), and NEGATIVE (-) to NEGATIVE ("X").

1. Connect clamp of plus-cable to positive (+) terminal (1) of discharged battery.
2. Connect clamp on opposite end of cable to positive (+) terminal (2) of booster battery.
3. Connect clamp of minus-cable to negative (-) terminal (3) of booster battery.
4. Connect clamp on opposite end of cable to a bare metal part bolted directly to the engine block or to the engine block itself (4) of car with discharged battery.
5. Start engine in the usual manner. If engine fails to start, do not continue to crank but contact nearest workshop.
6. With engine running, remove jumper cables from cars in exact order: Steps 4 through 1.

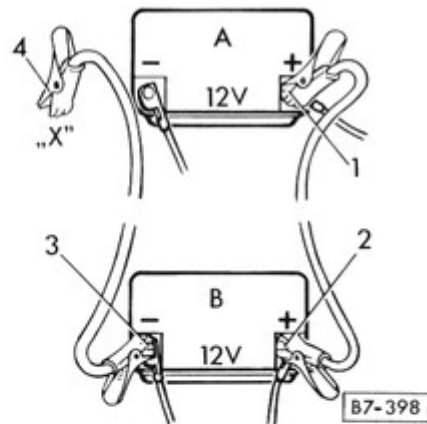

A – DISCHARGED BATTERY
B – BOOSTER BATTERY
X – to ground on engine block

Cars with Catalytic Converter/Automatic Transmission:

Do not push or tow to start. Damage to the catalytic converter, the transmission and/or other parts of the car may result.

See also WARNINGS on page 68.

See page 23 for "Emergency start assist"

Troubleshooting

Your Audi should repay you with troublefree driving if it receives regular maintenance and proper care. Should you ever encounter difficulties in starting your engine or have trouble on the road, there are a few repairs which you can make to get your car going again.

- If you are not familiar with proper repair procedures, do not attempt the checks or repairs described on these pages.
- Move disabled car well off the road. Turn on emergency flasher lights. If necessary, mark vehicles with road flares or other warning devices.

● Always support your car with suitable stands if it is necessary to work underneath the vehicle.

● The jack supplied with the car is not adequate nor is it intended for this purpose.

● Be extremely cautious when working on any part of the car to prevent accidental injury. Remove neckties or necklaces; tie long hair back behind your head. Disconnect the battery ground cable after turning off the engine before working on the electrical or fuel system to prevent sparking. Only connect battery if this is necessary for certain tests.

The adjustment of idling and ignition timing requires special equipment and should only be carried out by an Audi dealer.

Locate the condition and probable cause of your trouble in the list on the following pages and follow the directions on what to do. If the trouble is serious or if you are uncertain as to its origin, be sure to see dealer or qualified mechanic as soon as possible.

See WARNINGS on page 68

| Conditions | Probable Cause | What to do |
|--|---|---|
| A— Car will not start, engine will not turn over or turns over too slowly. | <ol style="list-style-type: none">1. The Automatic Transmission selector lever is not in starting position.2. Run down or dead battery.3. Loose connections:<ol style="list-style-type: none">a – at batteryb – at starter4. Starter failure. | <ol style="list-style-type: none">1. Shift into Neutral or Park.2. Charge or replace battery. Check cause of high current consumption.3. Make sure that all connections are tight:<ol style="list-style-type: none">a – check connections at battery and ground strap, retighten as necessary.b – check starter solenoid connections.4. Contact nearest dealer. |

If you are not fully familiar with proper repair procedures, do not attempt the checks or repairs described on this page. See **WARNINGS** on page 68.

| Condition | Probable Cause | What to do |
|--|--|--|
| B – Engine turns over but will not start. | <ol style="list-style-type: none"> 1. Improper starting procedure. 2. No fuel in the tank. 3. Fuse for electric fuel pump burned out. 4. Dampness in engine compartment. 5. Dampness in distributor. 6. Spark plugs wet, sooty or dirty. 7. Other failure in ignition or fuel injection system. | <ol style="list-style-type: none"> 1. Refer to “Starting procedures”. 2. Fill up tank. 3. Replace fuse No. 5 in fuse box 4. Dry ignition coil, ignition wires and distributor components. 5. Remove distributor cap and rotor and dry them carefully with lint-free cloth, especially inside of cap. 6. Install new plugs and check electrode gaps (0.028 in./0.7 mm). 7. Contact nearest Audi dealer. |
| C – Warm engine hard to start, or car hard to start in winter. | <ol style="list-style-type: none"> 1. Improper starting procedure. 2. Failure in fuel injection system. | <ol style="list-style-type: none"> 1. Refer to “Starting procedures”. 2. Check all electrical and fuel connections in engine compartment for tightness. If engine still does not start, contact nearest Audi dealer. |
| D – Engine stutters, misfires and stalls after starting. | <ol style="list-style-type: none"> 1. Failure in ignition system. 2. Failure in fuel injection system. | <ol style="list-style-type: none"> 1. Refer to para. B 4 and B 5. 2. Check all electrical and fuel connections in engine compartment for tightness. If cause cannot be corrected, contact nearest Audi dealer. |

If you are not fully familiar with proper repair procedures, do not attempt the checks or repairs described on this page. See **WARNINGS** on page 68.

| Condition | Probable Cause | What to do |
|---|--|--|
| E – Engine at proper operating temperature stalls while driving car, especially when accelerating. | <ol style="list-style-type: none"> 1. Dirty spark plugs. 2. Failure in ignition system. 3. Failure in fuel injection system. | <ol style="list-style-type: none"> 1. Clean plugs, check for carbon deposits, replace plugs if necessary. 2. Refer to para. B 4 and B 5. 3. Contact nearest Audi dealer. |
| F – Engine knocks (pinging). | <ol style="list-style-type: none"> 1. Octane rating of gasoline not correct. 2. Incorrect ignition timing. | <ol style="list-style-type: none"> 1. Fill up tank with fuel of proper octane rating. See “Fuel supply”. 2. Ignition timing should be set to specifications. See your dealer. |
| <p>G – Engine heats up excessively while driving car - water temperature warning light flashes.</p> <p>WARNINGS</p> <ul style="list-style-type: none"> ● Fan may start spontaneously even with engine off. Keep face, fingers, hair or clothing away from fan blades. ● Let engine cool down sufficiently. Hot engine compartment components can burn skin on contact. | <ol style="list-style-type: none"> 1. Stop-and-go or mountain driving in hot weather and air conditioning. 2. Insufficient coolant. 3. Failure in radiator fan or thermo switch. 4. Ignition retarded. 5. Insufficient cooling due to foglights or insect screens, for example, on top of front bumper. | <ol style="list-style-type: none"> 1. Slow down and turn off air conditioner. Engine temperature should return to normal. If not, check other probable causes. 2. Add if necessary. 3. Turn off engine. Contact nearest dealer. 4. Ignition timing should be set to specifications by your dealer. 5. Remove such accessories. |
| H – Oil pressure warning light comes on and buzzer sounds while driving | Oil pressure too low. | Stop immediately, turn off engine and check oil level. If oil level is as required (see “Checking the oil level”), do not drive on, contact nearest dealer. |

If you are not fully familiar with proper repair procedures, do not attempt the checks or repairs described on this page.
See WARNINGS on page 68.

| Condition | Probable Cause | What to do |
|---|---|--|
| I – Alternator warning light comes on while driving. | 1. V-belt for alternator may be slipping or broken. 2. Alternator does not charge. | 1. Stop at once and turn off the engine and adjust or replace V-belt (see “ Adjusting or replacing V-belt ”). 2. If V-belt runs properly without slipping, turn off all unnecessary electrical equipment and drive to the nearest dealer, as otherwise the battery will soon run down. WARNING Do not touch V-belt when engine is running. |
| K – Brake warning light comes on with engine running and parking brake released. | Level in brake fluid reservoir is too low. | See “ Brake warning light ” and “ Function of brake system ” for what to do. |
| L – Strong fuel odor while parked or driving. | Leak at fuel cap, fuel lines or fuel evaporation control system. | Turn off engine. Check fuel cap, all lines and connections. Seal leaks if possible. Contact nearest Audi dealer. WARNING Never smoke or use an open flame that could ignite fuel vapors. |
| M – Strong odor of hot oil and increased engine noise. WARNING Do not operate vehicle if engine oil has splashed onto engine compartment components, FIRE HAZARD! | 1. Crankcase ventilation system disconnected or broken. 2. Oil leak 3. Loose or missing oil filler cap. | 1. Turn off engine. Reconnect crankcase ventilation hose, or replace if necessary. 2. Contact nearest Audi dealer. 3. Do not operate vehicle. Have car towed to nearest dealer. Engine compartment must be cleaned. |

EMISSION CONTROL SYSTEM

In the Interest of Clean Air

Pollution of our environment has become a problem that is of increasing concern to all of us. We urge you to join us in our efforts for cleaner air in controlling the pollutants emitted from the automobile.

Audi has long recognized its responsibilities not only toward its customers but also toward the public in general. We have developed an emission control system that controls or reduces those parts of the emission that can be harmful to our environment. Your Audi is equipped with such a system.

Audi warrants your new vehicle under the terms and conditions set forth in the Warranty and Maintenance booklet. You, as the owner of the vehicle, have the responsibility to provide regular maintenance service for the vehicle, as specified in the Maintenance Schedule, and to keep a record of all maintenance work performed. Authorized Audi dealers have trained mechanics and special tools to offer fast, efficient service.

How Emission Control Works

When an automobile engine is running, it uses energy generated through the combustion of a mixture of air and fuel. Depending on whether a car is driven fast or slow or whether the engine is cold or hot, some of the fuel (hydrocarbons) may not be burned completely but be discharged into the engine crankcase or exhaust system.

Additional hydrocarbons may enter the atmosphere through evaporation of fuel from the fuel tank. Some hydrocarbons released into the air contribute to undesirable pollution.

In addition, carbon monoxide (CO) and oxides of nitrogen (NOx) are formed during combustion and discharged into the exhaust system.

To reduce these pollutants, all Audis are equipped with a special emission control system.

Your Audi may have all or part of the following major components:

Controlled Combustion

The amount of pollutants emitted from an engine greatly depends on the combustion of the air/fuel mixture. Complete burning of the air/fuel mixture is, therefore, very important.

Your Audi is equipped with a precisely calibrated fuel injection system to assure a finely balanced air/fuel mixture under all operating conditions.

Crankcase Ventilation System

Through Crankcase Ventilation harmful emissions from the engine crankcase are not permitted to reach the outside atmosphere. These emissions are recirculated to the air cleaner. From here the emissions mix with the air/fuel mixture in the intake manifold and are later burned in the engine.

Catalytic Converter

The catalytic converter is an efficient "clean up" device built into the exhaust system of your car to further help reduce engine pollutants. Harmful carbon monoxide and hydrocarbons in the exhaust gas are chemically changed into harmless carbon dioxide and water vapors before they pass to the outside through the muffler.

The use of **unleaded fuel** is **critically important** for the life of the converter. Deposits from leaded gasolines and fuel additives containing sulfur, zinc, nickel or barium will ruin the catalyst and make it ineffective as an emission clean-up device. Therefore, **only unleaded gasoline without harmful additives must be used.**

The catalytic converter achieves the required reduction of harmful pollutants with the aid of a **lambda control system**. This system is designed to maintain close control of the air/fuel mixture ratio under all operating conditions. At an air/fuel mixture ratio of 14.5 to 1 ($\lambda = 1.0$), hydrocarbons (HC), carbon monoxide (CO) and oxides of nitrogen (NOX) can be controlled efficiently and simultaneously by the catalytic converter. If, at any time, the air/fuel mixture ratio is either below or in excess of $\lambda = 1.0$, pollutants increase.

Oxygen Sensor (OXS)

The **oxygen sensor**, installed in the exhaust manifold, continuously senses the oxygen content of the exhaust and signals the information to an electronic control unit. The control unit corrects the fuel injector operating time, so that the engine always receives an accurately metered air/fuel mixture. The **lambda control system** is monitored by the oxygen sensor (OXS) indicator light in the instrument panel (see page 27, OXS light).

FUEL EVAPORATION CONTROL

The sealed Audi fuel evaporation system prevents gasoline vapors from escaping to the atmosphere through the following controls:

Fuel tank venting

An expansion chamber in the fuel tank and vent lines are part of the fuel tank vent system. These components prevent fuel from escaping to the outside at extreme high outside temperatures and when the car is driven or parked at an incline or any other non-level position.

Carbon canister

Vapors from the fuel tank are trapped in a canister filled with carbon. This canister is also connected to the fuel tank vent system.

This is how it works:

Fuel vapors pass through the canister and deposit hydrocarbons on the surface of the carbon. When the engine is running, fresh air entering the carbon canister through an opening, cleans the carbon and routes the hydrocarbons back to the engine where they are burned during normal combustion.

An important word of CAUTION on the Emission Control System in your car

To assure efficient operation of the Emission Control System:

Have your car maintained properly in accordance with the service recommendations listed in the Maintenance Schedule. Lack of proper maintenance, especially of the fuel and ignition systems, as well as improper use of the vehicle could lead to damage.

- Do not alter or remove any components of the Emission Control System unless approved by the manufacturer.
- Do not alter or remove any device, such as heat shields, switches, ignition wires or valves, which are designed to protect your vehicle's emission control system.
- Do not continue to operate your car if you detect engine misfire or other unusual operating conditions. This could result in overheating of the catalytic converter.

Starting

Do not leave car engine idling unattended after starting. If warning lights should come on to indicate improper operation, they would go unheeded. Extended idling also produces heat, which could result in overheating or other damage to the car.

Parking

As with any vehicle, do not park or operate your car in areas where combustible materials, such as dry grass or leaves, can come into contact with a hot exhaust system.

Undercoating – Warning

Do not apply additional undercoating or rustproofing on or near the exhaust manifold, exhaust pipes, catalytic converter or heat shields. During driving, the substance used for undercoating could overheat and cause a fire.

CARS WITH CATALYTIC CONVERTER

Do not turn the ignition off while the car is moving. Immediate damage to the catalytic converter will result if you turn the ignition off while your car is moving, or if you try to push-start the car. Under these conditions unburned fuel can reach the catalytic converter, which will make it ineffective as an anti-pollutant device.

TECHNICAL DATA

Engine

Four stroke, five cylinders in line, in front of front axle tilted to right, crankshaft with six main bearings, spur-belt overhead camshaft.

Water cooling, thermostatically-controlled, with electric fan, thermostatically operated.

Pressure oil feed with gear-type pump and full flow filter.

Electric fuel pump. CIS fuel injection system.

Paper element air cleaner with temperature sensitive intake air pre-heating.

Exhaust emission control system. Activated charcoal filter (carbon canister) in the fuel system.

| | |
|------------------------------------|--|
| - Maximum output SAE net | 130 hp at 5400 rpm |
| - Maximum torque SAE net | 142 ft lbs at 3000 rpm 192 Nm at 3000 rpm |
| - Displacement | 130.8 cu. in/2144 cm ³ |
| - Stroke | 3.40 in/86.4 mm |
| - Bore | 3.13 in/79.5 mm |
| - Compression ratio | 7.0:1 |
| Cooling system | Electric fan with thermo switch Water pump spur-belt driven |
| Fuel | “Unleaded fuel only” |

| | |
|--|--|
| Transmissions: | Automatic Transmission Automatic transmission with separate final drive. The transmission consists of a hydrodynamic torque converter and planetary gearing with three forward gears and one reverse. Front wheel drive with two constant velocity joints per drive shaft. |
| Body/Chassis: | All steel unitized body/chassis, passenger compartment. |
| Steering: | Rack and pinion steering (power assisted), energy absorbing steering wheel and column. |
| Front wheel suspension: | Independent FRONT WHEEL suspension: coil spring/shock absorber struts with negative steering roll radius, stabilizer bar. |
| Rear wheel suspension: | REAR WHEEL suspension: torsion crank axle with Panhard rod for lateral stability, progressive coil springs, telescopic shock absorbers. |
| Service (foot) brakes: | Power assisted, dual diagonal hydraulic system, disc brakes at front and rear. Brake wear indicators at front. Brake pressure regulator for the rear wheels. |
| Parking brakes: | Mechanical, effective on rear wheels. |
| Tires: | Steel belted radial tires 205/60 HR 15. |
| Wheel rim size and tire pressure: | Wheel rim size: Light alloy wheels 6 J x 15 Tire pressure: unloaded front 1.8 bar/26 psi rear 1.7 bar/26 psi loaded front 1.9 bar/28 psi rear 1.9 bar/28 psi |

Capacities

| | U.S. | Metric |
|--|----------|-------------|
| Fuel tank | 19.8 gal | 75.0 liters |
| Reserve of total capacity | 2.1 gal | 8.0 liters |
| Cooling system including heater | 10.0 qt | 9.4 liters |
| Engine oil (API/SE) | | |
| with filter change | 5.0 qt | 4.5 liters |
| without filter change | 4.5 qt | 4.0 liters |
| Oil capacity between upper and lower marks on dipstick | 1.1 qt | 1.0 liter |
| Automatic Transmission | | |
| at change (ATF) | 3.2 qt | 3.0 liters |
| final drive | 1.1 qt | 1.0 liter |
| (hypoid oil – does not have to be changed) | | |
| Windshield washer container | 1.8 qt | 1.7 liters |
| Power assisted steering | 0.8 qt | 0.8 liter |

Electrical system

| | |
|------------------------|--|
| Voltage | 12 Volts |
| Battery | 63 Ah/300 A |
| Starter | 1.5 hp/1.1 kW |
| Radiator fan | 350 watts |
| Alternator | 75 Amp/1050 watts 90 Amp/1260 watts |

Size of V-belts:

| | |
|---------------------------------------|-------------|
| for alternator | 9.5 x 800 L |
| for air conditioner | 12.5 x 915 |
| for power assisted steering | 12.5 x 992 |

| | |
|--------------------------------|---|
| Ignition distributor | with combined vacuum and centrifugal spark advance |
| Ignition system | Transistorized (breakerless) with integrated idle stabilizer system (ISS) |
| Firing order | 1 – 2 – 4 – 5 – 3 |
| Spark plugs | Bosch WR 7 DS Beru RS 35 Champion N 8 GY |

| | |
|-------------------------|-----------------|
| Plug thread | 14 mm |
| Electrode gap | 0.028 in/0.7 mm |

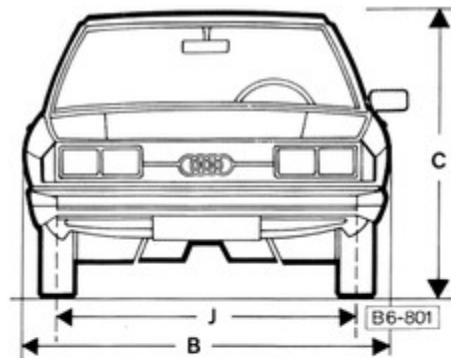
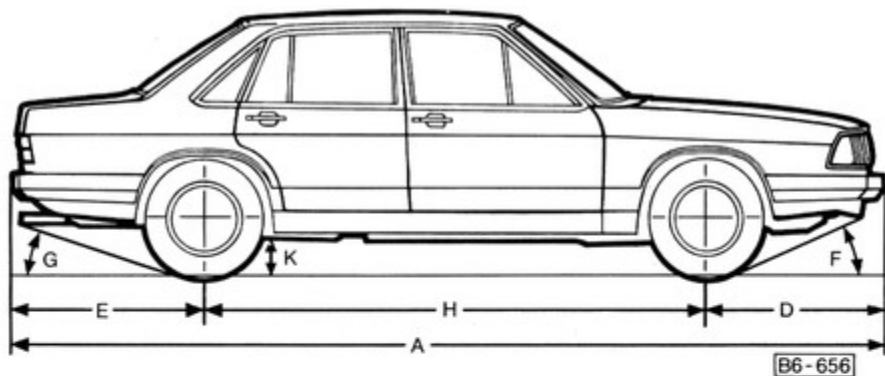

Dimensions

- A – 189.0 in/4798 mm
- B – 69.6 in/1768 mm
- C – 55.2 in/1392 mm (unloaded)
- D – 40.3 in/1023 mm
- E – 42.9 in/1090 mm
- F – 18°
- G – 15° (unloaded)
- H – 105.9 in/2688 mm (unloaded)
- J – 57.8 in/1466 mm
- K – 4.3 in/109 mm (loaded)

Turning circle, curb to curb
34 ft 2 in/10.43 m.

Weights

- Vehicle capacity weight see sticker on left doorjamb.
- Gross vehicle weight
- Gross axle weight, front
- Gross axle weight, rear } see Safety Compliance Sticker on the left door jamb.
- Permissible roof weight* 165 lb/75 kg

* Applies only to roof rack mounted to rain gutters. Distribute load evenly!

Lubricants

Engine oil – Petroleum based and/or SYNTHETIC based

Always use quality oil labeled “API Service SE or SF” for the engine of your Audi. Engine oils are graded according to their viscosity. The proper grade to be used in your engine depends on existing climatic or seasonal conditions.

The table on the right contains the grading for oils to be used in your Audi engine. As temperature ranges of the different oil grades overlap, brief variations in outside temperatures are no cause for alarm. It is also permissible to mix oil of different viscosities if you find it necessary to add oil.

Oil change intervals specified in the Warranty and Maintenance booklet accompanying the vehicle must be adhered to, including intervals for oil filter change.

Transmission oil

| Hypoid oil* | Single-grade | Multi-grade | Specifications |
|---|--------------|-------------|--------------------------|
| Final drive of the Automatic Transmission | SAE 90 | SAE 80W/90 | Mil-L-2105 B API/GL 5 |

* Does not have to be changed

Automatic Transmission and power assisted steering require ATF all year round. All ATFs labeled Dexron ® can be used.

Battery

Silicone spray or petroleum jelly should be used for the battery terminals and posts.

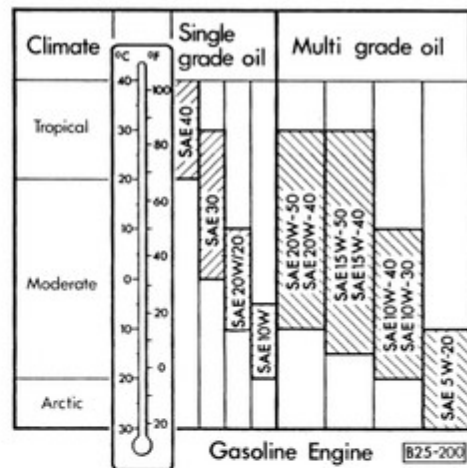

When using single grade SAE 10 W or multigrade SAE 5 W-20 engine oil avoid high speed long distance driving if the outside temperature rises above the indicated limit.

Lubricant additives

If your Audi is properly maintained, it is uneconomical to mix any type of additive with fuel, or lubricating oils and transmission fluids.

GAS STATION INFORMATION

Emergency towing by commercial tow truck

Cars with Automatic Transmission



B6-754



B6-755



B6-857

Tow with front wheels off the ground

Your car can be towed by a commercial tow truck using conventional sling-type gear.

Tow with front wheels on dollies

If excessive damage or other conditions prevent towing your car with front wheels off the ground, use wheel dollies.

DO NOT TOW with front wheels on the ground. Pulling the car backwards may cause serious damage to the car.

Never allow passengers to ride in a towed vehicle for any reason.

Lifting car

Lifting car with workshop hoist

Make sure there is sufficient clearance between pads and vehicle before driving car on to hoist, especially if the vehicle has a large front panel or spoiler.

The car must be lifted only at the lift points illustrated.

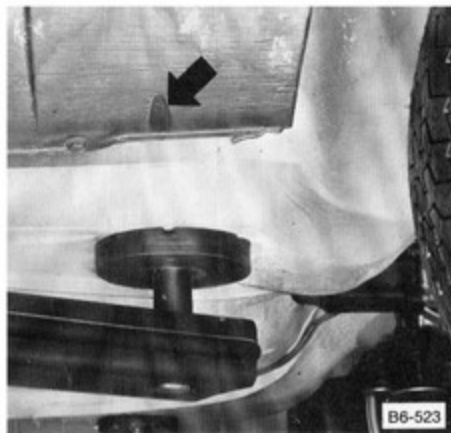

The front lift points are located on the underbody, where the door hinge pillar is welded to the chassis frame rail.

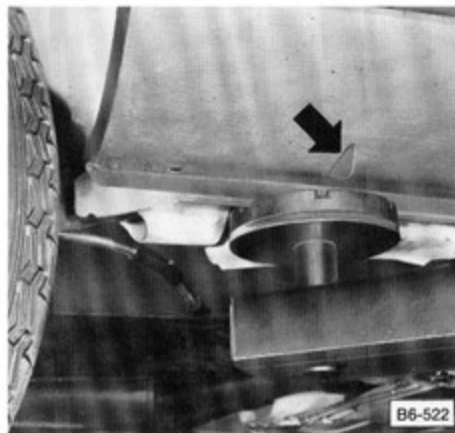

The rear lift points are located below the triangle mark in front of the rear wheel well.

Take care to avoid damaging critical components which are close to the lift points. This applies especially to the electric fuel pump.

Lifting car with floor jack

The same lifting points as illustrated for the hoist also apply when using a floor jack. To avoid damage to the underbody or chassis frame, it is necessary to insert a rubber pad between the floor jack and the lift points.

Vehicle should never be jacked up from underneath the engine oil pan, the transmission housing, or the rear axle. This could lead to serious damage.

If the battery is located under the left side of the rear seat, avoid damaging the battery by improperly positioning hoist or floor jack.

Lifting car with car jack

The car jack must never be used as a support to work underneath the car. If the jack is accidentally dislodged, you could be seriously injured. When working under the car always use safety stands specifically designed for this purpose.

Refer to the "Wheel changing procedure" detailed in this manual.

Starting the engine

Automatic Transmission:

Start with selector lever in Neutral or Park.

Fuel injection engine:

Always depress accelerator pedal slightly when starting. This applies at any outside temperature.

Emergency starting

A vehicle with Automatic Transmission cannot be started by pushing or towing. See page 78 for "Emergency starting with jumper cables".

Vehicle identification number (VIN)

Visible through driver's side of windshield.

Fuses and relays

On left under engine hood. See page 56.

Fuel: UNLEADED FUEL ONLY

Fuel cap: right rear panel

Engine hood release

Pull lever on left underneath dashboard.
Pull safety hook under hood. Lift hood.

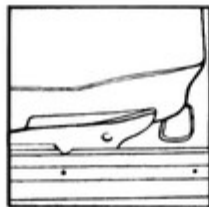

Front seats

Seat adjustment:
Pull lever in front of seat.

Jack

Jack is on right side of luggage compartment. It is held by a bolt and wing nut.

Tools

are packed in a bag which is stored in a recess behind jack on right side of luggage compartment.

Spare wheel

It is located in a recess underneath luggage compartment mat.
The tire pressure for the compact spare tire is 60 psi (4.22 kg/cm²) or 4.2 bar.

Tire pressure

See sticker on inside of fuel tank flap.

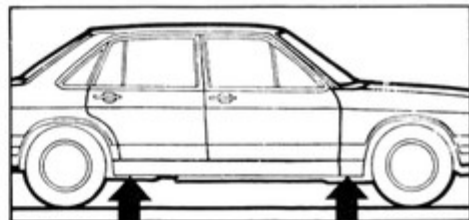

Jack points – two on each side

Only raise car at points indicated.

Engine oil dipstick

Vehicle must be on level ground. Wait at least 5 minutes after engine has stopped before checking oil level. Level should be between upper and lower marks on dipstick. Difference between marks is approx. 1 U.S. qt/1 liter.

Engine oil filler cap

The oil filler cap must be secure to avoid oil spill fire hazard.
Use quality oil labeled "API Service SF or SE". Oil viscosity chart page 90.

This page was
originally left Blank

This page was
originally left Blank

This page was
originally left Blank

At a glance . . .

| | |
|---|----------------------------------|
| ENGINE | |
| Horsepower SAE net | 130 hp at 5400 rpm |
| No. of cylinders | 5 |
| Displacement | 130.8 cu in/2144 cm ³ |
| Type | in line, front mount |
| Cooling | water-cooled |
| Fuel/air supply | CIS fuel injection |
| Fuel tank capacity | 19.8 U.S. gal./ 75 liters |
| Engine oil capacity with filter change | 5.0 U.S. qt/ 4.5 liters |
| without filter change | 4.5 U.S. qt/ 4.0 liters |

| | |
|-----------------|------------------|
| VEHICLE LENGTH. | 189.0 in/4798 mm |
| WIDTH | 69.6 in/1768 mm |
| HEIGHT. | 55.2 in/1392 mm |
| (unladen) | |

| | |
|----------------------|---|
| BRAKES. | dual diagonal circuits, power-assisted, discs front and rear |
| SUSPENSION | front wheels; independent rear wheels: torsion crank axle with Panhard rod. |
| STEERING | rack-and-pinion, power-assisted |

| | |
|-----------------------------|----------------------|
| DRIVE TRAIN | |
| Type | front wheel drive |
| Speeds (Automatic). | 3 forward, 1 reverse |

| | |
|----------------------------|--|
| ELECTRICAL SYSTEM. | 12 Volt |
| Battery | 63 Ah/300 A |
| Alternator | 75 Amp/1050 watts 90 Amp/1260 watts |

North America
4/82

www.audi-klassik.de